

URETHANE TOOLING & ENGINEERING CORP

**TOOL-A-THANE URETHANE
PRODUCTS, PRICES & DESIGN
INFORMATION**

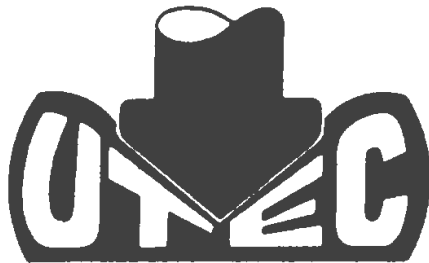

**MANUFACTURERS AND SUPPLIERS OF URETHANE
STOCK, MATERIALS, CUSTOM PARTS, TOOLS,
FIXTURES, DIES, RELATED PRODUCTS,
AND ENGINEERING SERVICES**

URETHANE TOOLING & ENGINEERING CORP

**PHONE: 1 (615) 510-3009
FAX: 1 (615) 510-3010
WEB SITE: www.urethanetooling.com
E-MAIL utec@urethanetooling.com**

INDEX

Cover, Front	1
Catalog Index	2
Custom Tool-A-Thane Urethane Parts	3
Custom Tool-A-Thane Urethane Forming Die	3
Engineering, Developments, & Fabrications	
Tool-A-Thane Concept	4
Tool-A-Thane Materials Formulations List	5
Physical Properties Tool-A-Thane	6, 7
Tool-A-Thane Sheets	8
Tool-A-Thane Rounds & Bars	9
Tool-A-Thane Springs & Strippers	10, 11, 12, 13, 14
Tool-A-Thane Pressure & Deflection	15, 16
Tool-A-Thane Round & Bar Pressure Chart	17
Tool-A-Thane Tool-O-Die Film	18
Tool-A-Thane Custom Wiper/Squeegee	18
Tool-A-Thane Wipers Blades, Adhesive &	19
Double Faced Tape	
Tool-A-Thane Wipe Up Die	19, 20
Tool-A-Thane Exact-A-Form Pads	20, 21
Tool-A-Thane Exact-A-Form Dies,	22
90 Degree & 30 Degree Acute	
Tool-A-Thane Press Brake Die Retainers	23, 24
Tool-A-Thane Forming Die Pads & Cushions	25
for Press Brake Die Retainers	
Tool-A-Thane Spring Gages for Press Brake	26
Die Retainers	
Tool-A-Thane "Split Pads"	27
Tool-A-Thane/Steel Wipe Down Die	27 & 28
Tool-A-Thane Form/Emboss/Blank Die	28
Springback Development Systems	29, 30, 31, 32, 33
Advantages of Using Tool-A-Thanes	34
Tool-A-Thane Die Designs	34, 35, 36, 37, 38, 39, 40
Notes	41
Quote Request Tool-A-Thane, Custom or	42
Standard	
Quote Request Forming Dies & Engineering	43
Services	
Ordering	44

CUSTOM TOOL-A-THANE URETHANE PARTS

Submit your part requirements; include the following for evaluation and quotation purposes:

- 1) Detailed Print/Sketches
- 2) Quantity per month-year
- 3) Grade or Hardness
- 4) Samples, if any

Based on the above quote will be submitted:

- 1) Prices with quantity breaks
- 3) Deliveries & Terms
- 4) Prices will be held for one year from date of quotation
- 5) Orders accepted on one year basis hold for release
- 6) Orders with predetermined deliveries accepted for scheduled deliveries extended out for two years



Utec only uses high performance urethane materials; no low cost/cheap urethane chemicals.

You will receive pricing, terms, & deliveries that are more than competitive; we do guarantee the price is less than you nearest pricing with equal materials being used.

Tool-A-Thane Urethane Shop for manufacturing of urethane molds, machining of urethane parts.

CUSTOM TOOL-A-THANE URETHANE FORMING DIE ENGINEERING, DEVELOPMENT, FABRICATION, TRYOUT



Tool-A-Thane Urethane Shop for Forming Die Design, Development, Fabrication of tools, & tryout. Submit your forming die request to Utec for price processing.

THE URETHANE CONCEPT IN METAL FORMING: Urethane is not a material to be used in metal forming work to eliminate all of the problems; moreover, urethane should be used where its use will aid in some fashion to help produce a better quality part or a more economical die, which may result in the lower production cost. Urethane can be used to great advantage in prototype tools as well as production tools, depending on the application. The concept is simple; urethane is used as one half of a die (either the male section or the female section, depending on the application). The urethane half normally need not be shaped to the exact shape of the opposite half of the die, as it is a flexible, non compressible, material and will take a given shape when moved, squeezed, or penetrated into.

WHY TOOL-A-THANE URETHANE: Each grade or formulation is a result of tests made with various types of forming dies to produce a urethane material that will stand up best under the unique stresses and strains that these types of dies will produce. Selecting the proper brand of urethane is as important as using the proper design for the die. It is therefore very important that the urethane decided upon for use in dies be material developed for the tooling and manufacturing industry, not for example, for the industrial tire industry.

WHY UTEC: UTEC brings to your door the complete range of Tool-A-Thane urethane products, related products, and services necessary for you to properly use the urethane concept. If all you desire is the material, we can fill your needs quite nicely, as we carry the largest selection presently available. If your needs are for design assistance, where you wish to build the urethane die yourself, we can and will help to insure that your die has the very best chance of functioning properly. Finally, if your need is for the whole package to be handled, including the die tryout and submitting of samples to you, we bring many years of fine service in this area. UTEC is in a position to handle the design, development, fabrication, and tryout of any die that it recommends. Both small tooling problems and large tooling programs are handled with service and dependability the prime consideration.



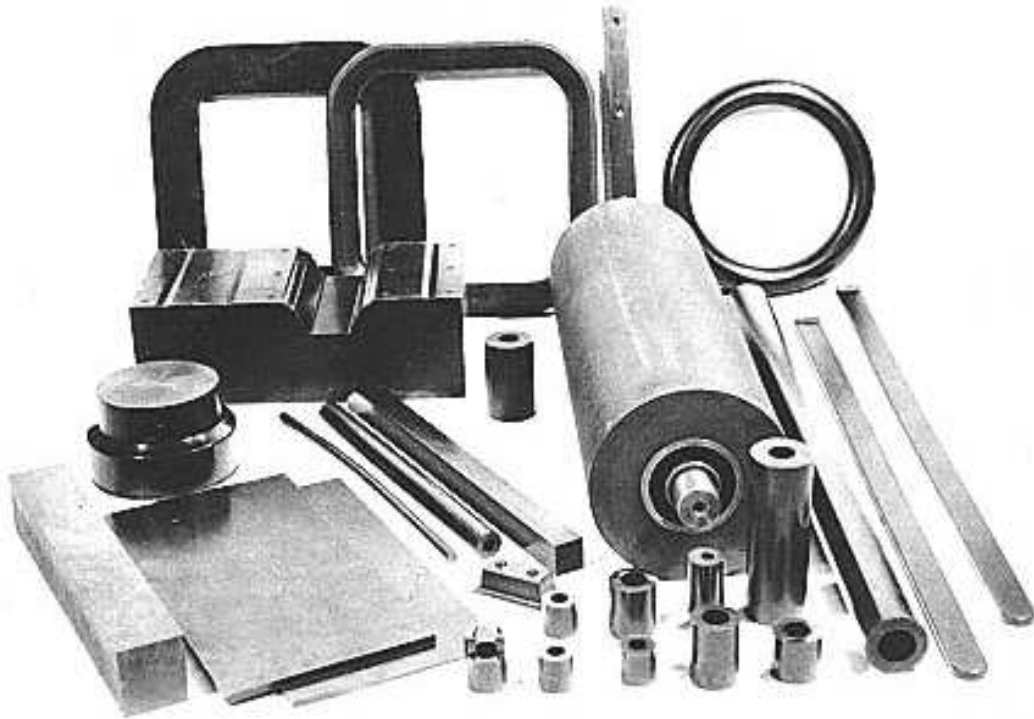

TOOL-A-THANE URETHANE STOCK MATERIAL LIST

FORMULATION SELECTIONS

UT-5 Tool-A-Thane 5% Deflection for optimum life -- Hardness 79 Shore D -- Greatest abrasion and wear resistance -- Excellent machinability -- Highest load-bearing capacity -- closest to steel replacement in standard forming operations i.e. matching dies, blocks, jaws, etc.

UT-10 Tool-A-Thane 10% Deflection for optimum life -- Hardness 60 Shore D -- High abrasion and wear resistance -- Good machinability -- High load-bearing capacity -- Special forming applications.

UT-15 Tool-A-Thane 15% Deflection for optimum life -- Hardness 95 Shore A -- Best tear strength and cut resistance -- High load-bearing capacity -- Definition with less penetration -- Generally used for forming heavier and tougher metals.

UT-25 Tool-A-Thane 25% Deflection for optimum life -- Hardness 90 Shore A -- Good load-bearing capacity and best abrasion and wear resistance -- best general purpose material.

UT-35 Tool-A-Thane 35% Deflection for optimum life -- Hardness 80 Shore A -- Lower load-bearing capacity -- Best for lighter gages and softer materials.

FORMULATION SELECTIONS

UT-703 35% Deflection for optimum life -- Hardness 75 Shore A -- Low load-bearing capacity -- Best for very light gages and very soft materials.

UT-605 35% Deflection for optimum life -- Hardness 65 Shore A -- Low load-bearing capacity -- Best for extremely light gages and extremely soft materials.

UT-505 Hardness 55 Shore A -- Lowest load-bearing capacity -- Not for forming applications.

UT-405 Hardness 45 Shore A -- Limited special applications

UT-305 Hardness 35 Shore A -- Limited special applications

UT-Special Formulations Formulation changes can change properties resulting in extremely high qualities in one or more specific properties for special or extremely abusive applications. Other durometer materials available. Please consult factory for specifics.

P H Y S I C A L	P R O P E R T I E S O F			
	<u>UT-5</u>	<u>UT-10</u>	<u>UT-15</u>	<u>UT-25</u>
100% Modulus, psi	3700	2500	1760	1090
300% Modulus, psi	----	6700	3675	2200
Tensile Strength, psi	7600	7250	6200	4900
Elongation at Break, %	250	350	385	445
Hardness, Durometer Shore A	--	98	95	90
Hardness, Durometer Shore D	75	62	48	40
Specific Gravity @ 75F	1.118	1.090	1.071	1.058
Tear Strength, D-470, lb/in	105	125	95	65
Tear Strength, Graves, lb/in	1080	850	700	515
Compression Set, Method B, %, 22 hours at 158 degrees F	53	42	36	33
Linear Shrinkage, %	1.8	1.7	1.7	1.5
Brittleness Temperature, degrees F	-90	-90	-90	-90
Recommended % Penetration for optimum life	5	10	15	25
Abrasion Resistance, NBS Index	470	375	275	175
Coefficient of Friction, on 125 rms steel at 20 lbs load at 52 fpm	.22	.30	.50	.68
Bayshore Resistance, NBS Index	53	55	47	50

**MACHINING THE VARIOUS GRADES OF
TOOL-A-THANE URETHANE**

The harder the urethane the easier it is to machine. Grade UT-5 is readily machinable, but the softer grades, such as 50 Durometer Shore A are extremely difficult to machine. Where possible the very soft grades should be cast to shape to eliminate any possible machining operations. For specific machining instructions consult UTEC for assistance as to cutting speeds, cutting feeds, types of tools (cutting), etc.

TYPICAL USES FOR TOOL-A-THANE URETHANES

Forming Pads	Forming Mandrels	Couplings
Wiping Pads	Gaskets & Seals	Wheels & Tires
Bulging Pads	Diaphragms	Drive Rolls
Springs & Strippers	Clamping Fixtures	Forming Rolls
Pressure Pads	Liner Pads	Bushings
Bumpers	Gears	Machine Mounts

T O O L - A - T H A N E U R E T H A N E S

<u>UT-35</u>	<u>UT-705</u>	<u>UT-605</u>	<u>UT-505</u>	<u>UT-405</u>	<u>UT-305</u>
615	525	325	315	285	42
1160	1050	850	770	670	60
6600	6000	5400	4600	4000	NA
650	575	470	440	400	>800
80	75	65	55	45	35
32	--	--	--	--	--
1.220	1.220	1.220	1.220	1.220	1.213
125	60	45	30	15	6
450	350	275	240	215	43
38	--	--	--	--	--
1.5	1.5	1.5	1.5	1.5	1.4
-90	-90	-90	-90	-90	-90
35	40	40	40	40	40
110	<50	<50	<50	<50	<50
.80	>.80	>.80	>.80	>.80	>.80
38	NA	NA	NA	NA	NA

URETHANE PRECISION SHEET STOCK

Thickness

W x L	1/16"	1/8"	3/16"	1/4"	3/8"	1/2"	5/8"	3/4"	1"
1 x 48	13.53	20.92	22.16	23.63	25.73	30.78	35.47	41.26	69.80
2 x 48	18.37	25.63	30.78	34.23	42.10	53.17	62.17	69.42	89.86
3 x 48	24.38	31.01	36.56	42.56	58.60	70.93	84.21	98.50	127.66
4 x 48	31.28	39.04	44.34	54.39	76.22	93.47	109.35	131.24	165.46
6 x 6	11.10	16.88	18.36	19.95	21.68	24.04	28.32	32.02	40.88
6 x 12	17.01	23.28	26.60	29.32	33.24	41.75	49.86	55.92	70.93
6 x 18	19.99	27.95	32.52	35.95	45.93	57.26	66.49	77.81	95.77
6 x 24	24.38	31.01	36.56	42.56	58.60	70.93	84.21	98.50	127.66
6 x 36	33.97	42.56	48.90	59.83	83.86	103.80	123.02	143.72	180.85
6 x 48	42.10	55.04	63.90	78.04	106.39	134.83	159.54	186.14	241.18
12 x 12	24.38	31.01	36.56	42.56	58.60	70.93	84.21	98.50	127.66
12 x 18	33.97	42.56	48.90	59.83	83.86	103.80	123.02	143.72	180.85
12 x 24	42.10	55.04	63.90	78.04	106.39	134.83	159.54	186.14	241.18
12 x 36	61.34	79.77	91.73	111.81	151.67	191.55	232.69	271.32	340.40
12 x 48	79.77	102.90	119.55	141.81	192.29	255.34	310.25	361.72	453.91
18 x 18	46.92	60.81	69.71	85.81	116.69	147.65	179.50	209.41	263.34
18 x 24	61.34	79.77	91.73	111.81	151.67	176.23	232.69	271.32	340.40
18 x 36	87.66	113.76	128.75	155.63	215.46	279.23	344.11	400.99	494.91
18 x 48	114.40	146.27	167.59	202.15	287.25	372.28	452.27	526.55	606.30
24 x 24	79.77	102.92	119.55	141.81	192.29	255.34	310.25	361.72	453.91
24 x 36	114.40	146.27	167.59	202.15	287.25	372.28	452.27	526.55	606.30
24 x 48	145.40	184.41	218.16	262.36	372.28	480.52	550.86	638.18	808.48

Thickness

W x L	1-1/4"	1-1/2"	2"	2-1/2"	3"	3-1/2"	4"
1 x 48	62.17	69.42	89.86	112.26	118.21	157.25	179.72
2 x 48	112.26	134.73	152.74	206.82	234.37	267.29	305.48
3 x 48	159.54	191.49	234.37	290.17	372.28	410.15	468.74
4 x 48	206.82	248.19	330.92	412.63	496.39	579.12	661.84
6 x 6	47.05	53.17	70.93	88.64	95.77	124.14	141.87
6 x 12	83.39	95.77	127.66	159.54	180.85	223.41	255.32
6 x 18	120.35	143.72	180.85	226.04	263.34	316.49	361.69
6 x 24	154.24	180.85	241.18	292.51	340.40	422.07	482.37
6 x 36	221.51	263.34	340.40	425.46	494.65	595.70	680.80
6 x 48	290.17	340.40	453.91	531.83	606.30	794.34	907.82
12 x 12	154.24	180.85	241.18	292.51	344.26	422.07	482.37
12 x 18	221.51	263.34	340.40	425.46	494.65	595.70	680.80
12 x 24	290.17	340.40	453.91	531.83	606.30	794.34	907.82
12 x 36	416.74	494.91	606.30	757.88	909.56	1061.03	1212.60
12 x 48	529.03	606.30	808.50	1010.50	1212.63	1414.87	1616.99
18 x 18	322.43	382.99	494.91	568.51	682.17	866.09	989.82
18 x 24	416.74	494.91	606.30	757.88	909.56	1061.03	1212.60
18 x 36	587.87	682.17	909.56	1141.69	1364.20	1591.73	1819.12
18 x 48	757.28	909.56	1212.63	1407.05	1818.93	2122.11	2425.27
24 x 24	529.03	606.30	808.50	1010.50	1212.63	1414.87	1616.99
24 x 36	757.28	909.56	1212.63	1515.74	1818.93	2122.11	2425.27
24 x 48	1025.20	1212.64	1616.84	2021.00	2425.27	2720.77	3233.67

For UT-5,UT-703,UT-605,UT-505,UT-405,UT-305 add 10% to above prices

URETHANE SOLID ROUNDS

Length

Diameter	3"	6"	12"	24"	36"	48"
1/4"	2.70	5.07	10.10	20.22	-----	-----
3/8"	2.70	5.29	10.47	20.93	31.39	41.88
1/2"	2.70	5.42	10.86	21.68	32.01	43.33
5/8"	3.09	5.67	11.32	22.66	33.97	45.30
3/4"	3.70	6.91	13.71	24.99	36.43	46.92
7/8"	4.33	8.62	14.66	27.12	39.53	51.96
1"	4.91	9.51	16.41	30.65	44.81	58.99
1-1/4"	6.16	11.96	21.07	39.90	58.85	77.54
1-1/2"	8.01	15.13	27.58	52.10	76.59	91.95
1-3/4"	9.86	18.15	35.72	65.24	86.79	104.34
2"	11.96	22.78	42.48	76.09	97.36	114.24
2-1/2"	19.85	37.22	54.39	99.59	136.17	181.24
3"	25.86	47.54	75.99	139.26	208.79	278.48
3-1/2"	28.92	53.55	97.47	178.76	-----	-----
4"	39.65	68.22	127.85	227.41	-----	-----
5"	53.23	97.98	179.03	349.27	-----	-----
6"	76.72	135.81	257.55	457.55	-----	-----
7"	96.02	175.30	342.28	666.81	-----	-----
8"	120.05	223.80	436.05	872.11	-----	-----

For UT-5,UT-703,UT-605,UT-505,UT-405,UT-305 add 10% to above prices

URETHANE SQUARE & RECTANGULAR BARS

Height x Width	2" Blocks	12"	24"	36"	48"
1/2" x 1/2"	1.39	8.50	17.00	-----	-----
1/2" x 1"*	1.68	8.07	16.14	24.21	32.28
3/4" x 3/4"	2.54	10.48	20.96	-----	-----
1" x 1"	3.37	16.14	32.28	48.42	64.56
1" x 2"*	3.54	20.75	41.50	62.25	83.00
1-1/2" x 1-1/2"	7.01	28.12	56.24	84.36	112.48
2" x 2"	7.09	41.50	83.00	124.50	166.00
2" x 3"	10.37	63.00	126.00	189.00	252.00
3" x 3"	17.30	73.20	146.40	219.60	292.80
4" x 4"	29.53	120.50	241.00	-----	-----
5" x 5"	50.52	195.80	-----	-----	-----
6" x 6"	72.75	281.94	-----	-----	-----

For UT-5,UT-703,UT-605,UT-505,UT-405,UT-305 add 10% to above prices

* Split Pad

TOOL-A-THANE URETHANE SPRINGS AND STRIPPERS

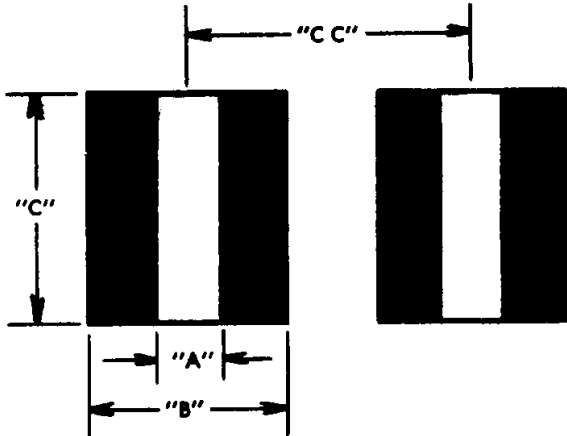

Definitions :

- "A" Inside Diameter, Fits Punch Diameter as ring fit
 - "B" Diameter of spring
 - "C" Free Standing Length (Height) of Spring
 - "CC" Minimum Spacing Center to Center of Springs
- When Ordering Specify: Quantity, Catalog Number, I.D. ("A"), O.D. ("B"), and Length ("C").

ADVANTAGES OF URETHANE SPRINGS AND STRIPPERS

High Tear Resistance	Oil Resistant
High Load Bearing Capacity	No Marring
Excellent Vibration Dampening	No Shrapnelizing
Excellent Flex Life	

Easy installation -- Ring fit over punch body diameter of dowel pin diameter
Close center to center distance - 1/4" to 3/8" in diameter larger than spring O.D. depending deflection % and spring diameter
Springs obtain up to 2600 lbs. per 1/8" deflection as compared to 500 lbs. per 1/8" deflection for standard heavy duty steel springs

PHYSICAL PROPERTIES OF URETHANE SPRINGS & STRIPPERS

Hardness: 95 Durometer Shore A & 50 Durometer Shore D
Tensile strength: 5200 psi
Elongation: 400%
Tear Strength: 150-ASTM D-470, lb./in., split or 600-ASTM D-624, lb./in. Die C
Abrasion Resistance: NBS Index, 275
Compression Set: 45%, Method B (22 Hours @ 158 degrees F.)
Resilience: 40% (Yersley %)
Brittleness Temperature: -90 degrees F

OPERATING SPEEDS & % DEFLECTION

Short Run or Slow Speed -- Up to 200 strokes per hour -- above 25% of height

Intermittent -- Up to 700 strokes per hour -- up to 25% of spring height

Continuous -- Up to 12,000 strokes per hour -- up to 15% of spring height

CUTTING OF URETHANE SPRINGS & STRIPPERS

Bandsawing: Use any type conventional saw with 4 hook (sharp) carbon blade with raker set

Lathe cutting: Use H.S.S. Tool Bits with positive rake from 5 to 10 degrees

Shearing : Consult Factory - recommended medium to high production cutting

HEAT BUILDUP OF URETHANE SPRINGS & STRIPPERS

Heat buildup is a major cause of premature breakdown. This is a direct function of effective strokes per hour and % deflection of the urethane. Always select spring that will give minimum deflection % for job.

MINIMUM CENTER TO CENTER DISTANCE

This is the closeness that two or more springs can be placed. Urethane springs and strippers can not be placed side by side since urethane is a noncompressible material. When compressed the O.D. of the spring must be free to bulge to allow for the displaced urethane by the reduction in height of the spring or stripper. In the case of Tool-A-Thane Springs and Strippers the amount of the area left available is a function of the size of the spring and the amount of the deflection. Normally 1/8" to 3/16" must be left around the O.D. of a spring.

OTHER TOOL-A-THANE PRESSURING METHODS:

Other shapes than tubes can be used for developing pressures. Bar stock and Sheets are used where pressures above 2600 lb./1/8" deflection are required. Consult factory for further data or assistance for determining these requirements.

LIGHT DUTY SPRINGS AND STRIPPERS

Catalog No.	"A" I.D.	"B" O.D.	"C" Length	lbs/ 1/8" Defl.	"CC" Min. Ctr to Ctr	Price
250L1	1/4	3/4	1	325	1	2.04
250L2	1/4	3/4	1-1/4	250	1	2.29
250L3	1/4	3/4	1-1/2	215	1	2.61
250L4	1/4	3/4	1-3/4	183	1	2.89
250L0	1/4	3/4	12		1	19.00
375L1	3/8	7/8	1	444	1-1/8	2.37
375L2	3/8	7/8	1-1/4	347	1-1/8	2.74
375L3	3/8	7/8	1-1/2	275	1-1/8	3.14
375L4	3/8	7/8	1-3/4	224	1-1/8	3.49
375L5	3/8	7/8	2	199	1-1/8	3.98
375LX	3/8	7/8	12		1-1/8	19.00
500L1	1/2	1	1	512	1-1/4	2.64
500L2	1/2	1	1-1/4	340	1-1/4	3.03
500L3	1/2	1	1-1/2	325	1-1/4	3.49
500L4	1/2	1	1-3/4	275	1-1/4	3.93
500L5	1/2	1	2	250	1-1/4	4.45
500LX	1/2	1	12		1-1/4	20.00
625L1	5/8	1-1/8	1	562	1-3/8	2.75
625L2	5/8	1-1/8	1-1/4	446	1-3/8	3.21
625L3	5/8	1-1/8	1-1/2	375	1-3/8	3.70
625L4	5/8	1-1/8	1-3/4	323	1-3/8	4.15
625L5	5/8	1-1/8	2	295	1-3/8	4.76
625LX	5/8	1-1/8	12		1-3/8	20.00
750L1	3/4	1-3/8	1-1/4	747	1-5/8	3.82
750L2	3/4	1-3/8	1-1/2	642	1-5/8	4.39
750L3	3/4	1-3/8	1-3/4	554	1-5/8	4.88
750L4	3/4	1-3/8	2	479	1-5/8	5.58
750L5	3/4	1-3/8	2-1/4	417	1-5/8	6.08
750LX	3/4	1-3/8	12		1-5/8	23.50
100L1	1	1-3/4	1-1/4	1137	2-1/8	4.58
100L2	1	1-3/4	1-1/2	940	2-1/8	5.24
100L3	1	1-3/4	1-3/4	788	2-1/8	5.87
100L4	1	1-3/4	2	689	2-1/8	6.72
100L5	1	1-3/4	2-1/4	616	2-1/8	7.29
100L6	1	1-3/4	2-1/2	548	2-1/8	7.96
100L7	1	1-3/4	2-3/4	505	2-1/8	8.78
100LX	1	1-3/4	12		2-1/8	24.40

Other sizes available on request

MEDIUM DUTY SPRINGS AND STRIPPERS

Catalog No.	"A" I.D.	"B" O.D.	"C" Length	lbs/1/8" Defl.	"CC" Min. Ctr to Ctr	Price
250M1	1/4	7/8	1	475	1-1/8	2.59
250M2	1/4	7/8	1-1/4	350	1-1/8	3.01
250M3	1/4	7/8	1-1/2	302	1-1/8	3.43
250M4	1/4	7/8	1-3/4	275	1-1/8	3.85
250M0	1/4	7/8	12		1-1/8	19.00
375M1	3/8	1	1	575	1-1/4	2.74
375M2	3/8	1	1-1/4	475	1-1/4	3.15
375M3	3/8	1	1-1/2	389	1-1/4	3.65
375M4	3/8	1	1-3/4	325	1-1/4	4.11
375M5	3/8	1	2	286	1-1/4	4.67
375MX	3/8	1	12		1-1/4	19.00
500M1	1/2	1-1/8	1	681	1-3/8	2.87
500M2	1/2	1-1/8	1-1/4	525	1-3/8	3.32
500M3	1/2	1-1/8	1-1/2	424	1-3/8	3.84
500M4	1/2	1-1/8	1-3/4	350	1-3/8	4.27
500M5	1/2	1-1/8	2	320	1-3/8	4.91
500MX	1/2	1-1/8	12		1-3/8	20.00
625M1	5/8	1-1/4	1	794	1-1/2	2.95
625M2	5/8	1-1/4	1-1/4	600	1-1/2	3.45
625M3	5/8	1-1/4	1-1/2	510	1-1/2	3.98
625M4	5/8	1-1/4	1-3/4	424	1-1/2	4.50
625M5	5/8	1-1/4	2	384	1-1/2	4.66
625MX	5/8	1-1/4	12		1-1/2	20.00
750M1	3/4	1-1/2	1-1/4	975	1-7/8	4.10
750M2	3/4	1-1/2	1-1/2	810	1-7/8	4.67
750M3	3/4	1-1/2	1-3/4	688	1-7/8	5.24
750M4	3/4	1-1/2	2	591	1-7/8	6.00
750M5	3/4	1-1/2	2-1/4	529	1-7/8	6.50
750M6	3/4	1-1/2	2-1/2	475	1-7/8	7.11
750M7	3/4	1-1/2	2-3/4	418	1-7/8	7.90
750MX	3/4	1-1/2	12		1-7/8	23.50
100M1	1	2	1-1/4	1550	2-3/8	5.21
100M2	1	2	1-1/2	1200	2-3/8	6.08
100M3	1	2	1-3/4	971	2-3/8	6.70
100M4	1	2	2	854	2-3/8	7.62
100M5	1	2	2-1/4	770	2-3/8	8.08
100M6	1	2	2-1/2	700	2-3/8	9.05
100M7	1	2	2-3/4	636	2-3/8	10.00
100M8	1	2	3	569	2-3/8	11.22
100M9	1	2	4	423	2-3/8	15.10
100MX	1	2	12		2-3/8	29.40

Other sizes available on request

HEAVY DUTY SPRINGS AND STRIPPERS

Catalog No.	"A" I.D.	"B" O.D.	"C" Length	lbs/1/8" Defl.	"CC" Min. Ctr. to Ctr	Price
250H1	1/4	1	1	712	1-1/4	2.84
250H2	1/4	1	1-1/4	547	1-1/4	3.26
250H3	1/4	1	1-1/2	399	1-1/4	3.76
250H4	1/4	1	1-3/4	348	1-1/4	4.21
250H0	1/4	1	12		1-1/4	19.00
375H1	3/8	1-1/8	1	800	1-3/8	2.95
375H2	3/8	1-1/8	1-1/4	593	1-3/8	3.45
375H3	3/8	1-1/8	1-1/2	522	1-3/8	3.97
375H4	3/8	1-1/8	1-3/4	450	1-3/8	4.47
375H5	3/8	1-1/8	2	367	1-3/8	5.13
375HX	3/8	1-1/8	12		1-3/8	19.00
500H1	1/2	1-1/4	1	863	1-1/2	3.15
500H2	1/2	1-1/4	1-1/4	675	1-1/2	3.66
500H3	1/2	1-1/4	1-1/2	550	1-1/2	4.22
500H4	1/2	1-1/4	1-3/4	492	1-1/2	4.77
500H5	1/2	1-1/4	2	450	1-1/2	5.47
500HX	1/2	1-1/4	12		1-1/2	20.00
625H1	5/8	1-3/8	1	975	1-5/8	3.18
625H2	5/8	1-3/8	1-1/4	775	1-5/8	3.70
625H3	5/8	1-3/8	1-1/2	640	1-5/8	4.27
625H4	5/8	1-3/8	1-3/4	546	1-5/8	4.85
625H5	5/8	1-3/8	2	489	1-5/8	5.59
625HX	5/8	1-3/8	12		1-5/8	23.00
750H1	3/4	1-3/4	1-1/4	1400	2-1/8	4.91
750H2	3/4	1-3/4	1-1/2	1200	2-1/8	5.67
750H3	3/4	1-3/4	1-3/4	1015	2-1/8	6.41
750H4	3/4	1-3/4	2	896	2-1/8	7.33
750H5	3/4	1-3/4	2-1/4	796	2-1/8	7.92
750H6	3/4	1-3/4	2-1/2	707	2-1/8	8.62
750H7	3/4	1-3/4	2-3/4	651	2-1/8	9.61
750HX	3/4	1-3/4	12		2-1/8	26.50
100H1	1	2-1/2	1-1/4	2593	2-7/8	8.39
100H2	1	2-1/2	1-1/2	2136	2-7/8	9.78
100H3	1	2-1/2	1-3/4	1796	2-7/8	11.00
100H4	1	2-1/2	2	1524	2-7/8	12.75
100H5	1	2-1/2	2-1/4	1316	2-7/8	13.83
100H6	1	2-1/2	2-1/2	1212	2-7/8	15.24
100H7	1	2-1/2	2-3/4	1106	2-7/8	16.90
100H8	1	2-1/2	3	996	2-7/8	19.14
100H9	1	2-1/2	4	734	2-7/8	26.12
100HX	1	2-1/2	12		2-7/8	47.50

Other sizes available on request

PRESSURE/DEFLECTION

Tool-A-Thane Urethanes have greater load bearing capacities than conventional elastomers of a similar hardness. This allows for pressuring designs with smaller parts with a savings of material costs and weight.

When a piece of urethane is squeezed between two parallel surfaces, the urethane will spread laterally, increasing the effective load bearing area. If the lateral movement is restricted in some fashion, this will greatly stiffen the urethane part. It should be noted that a piece with lubrication will greatly assist lateral movement.

Shape Factor: This is the ratio of the area of one loaded surface to the total area of the unloaded areas free to bulge.

Compression-Deflection Characteristics of Tool-A-Thane

Urethanes: As the shape factor increases the load required to produce a given strain increases. However, there is no mathematical relationship between the two. They must be determined empirically. The following three charts show compression-deflection curves for Tool-A-Thane UT-35, UT-25, and UT-15 with bonded surfaces. They are normally accurate to $\pm 10\%$.

Recommended deflections for optimum life: UT-35:35%;
UT-25:25%; UT-15:15%.

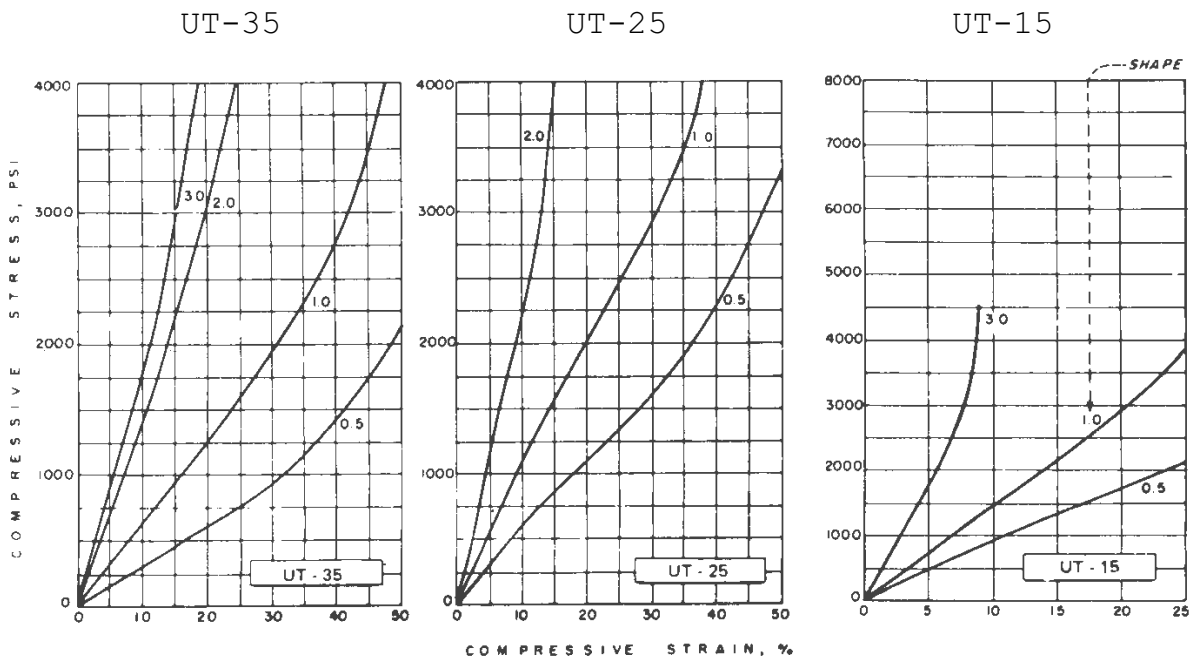

PRESSURE DEFLECTION

The following limitations should be used in considering uses for Tool-A-Thane Urethanes.

a) The piece must have parallel surfaces. b) Piece should have a thickness of not more than 2 times the smallest lateral dimension. c) Piece should have loaded surfaces restrained from lateral movement.

b) For Rectangular Shaped pieces use:

$$\text{Shape Factor} = \frac{LW}{2t(L+W)}$$

W = width

t = thickness

L = length

c) For Rounds or Tubes use:

$$\text{Shape Factor} = \frac{d}{4h}$$

d = diameter

h = height

Example: You want to know how much a pad 1/2" x 4 x 4 in UT-25 will deflect under 1000 psi compression stress:

$$\text{Shape Factor} = \frac{L(W)}{2t(L+W)} = \frac{4(4)}{2(1/2)(4+4)} = \frac{16}{8} = 2$$

In above charts we find the compressive stress-strain curve of a UT-25 piece with a shape factor of 2 crosses the 1000 psi stress abscissa at 4% strain; therefore pad will deflect 4% of thickness (1/2") or .020".

You now would like to know how much pressure would be developed if you deflect the same 1/2 x 4 x 4 UT-25 10% of its thickness. For a shape factor of 2 at 10% deflection the compressive stress line intersects at 2,250 psi.

Therefore the pressure developed at .050" deflection is 36,000.

In general the harder the Tool-A-Thane for the same shape the greater the pressure developed.

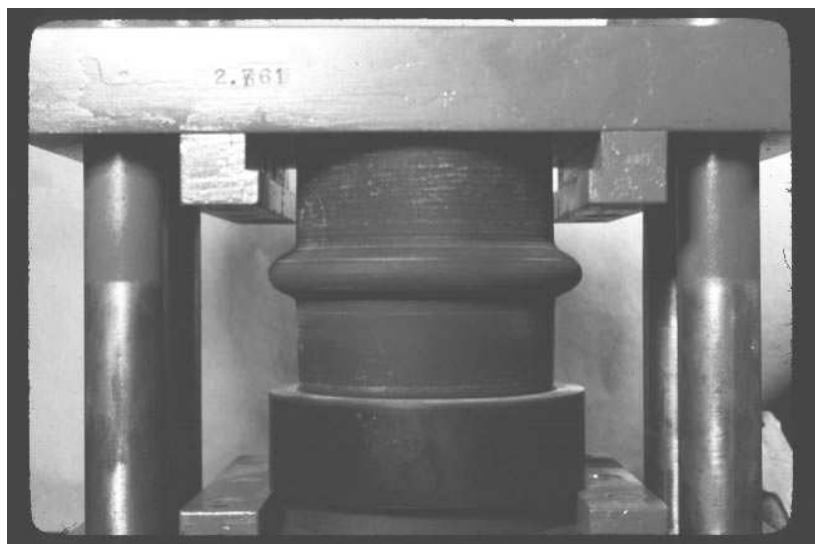

TOOL-A-THANE URETHANE ROUND & BAR PRESSURE CHART

	GRADE		
	UT-15	UT-25	UT-35
3" Diameter x 2" Height	2,735	1,835	1,035
3" Diameter x 3" Height	1,480	920	540
3" Diameter x 4" Height	1,200	735	540
4" Diameter x 2" Height	5,800	3,900	2,270
4" Diameter x 3" Height	2,760	1,840	1,060
4" Diameter x 4" Height	2,210	1,380	800
4" Diameter x 5" Height	1,630	1,000	580
5" Diameter x 2" Height	11,000	7,200	4,600
5" Diameter x 3" Height	4,720	3,200	1,900
5" Diameter x 4" Height	3,530	2,330	1,350
5" Diameter x 5" Height	2,550	1,625	930
6" Diameter x 2" Height	20,130	12,600	8,060
6" Diameter x 3" Height	7,680	5,240	3,160
6" Diameter x 4" Height	5,460	3,660	2,110
6" Diameter x 5" Height	3,810	2,475	1,480
7" Diameter x 2" Height	32,000	20,530	13,000
7" Diameter x 3" Height	12,200	8,000	4,920
7" Diameter x 4" Height	7,830	5,400	3,000
7" Diameter x 5" Height	5,750	3,560	2,110
8" Diameter x 2" Height	52,000	31,500	19,300
8" Diameter x 3" Height	18,100	11,700	7,400
8" Diameter x 4" Height	11,500	7,780	4,500
8" Diameter x 5" Height	7,500	5,000	3,000
1" Height x 1" Wide x 12" Lg.	10,000	6,800	4,000
2" Height x 2" Wide x 12" Lg.	9,800	6,700	3,900
3" Height x 2" Wide x 12" Lg.	5,400	3,500	2,050
2" Height x 3" Wide x 12" Lg.	22,000	14,500	8,500

Above values are in lbs. per 1/8" deflection. Recommended Percent Deflection of "Height": UT-15 = 15%, UT-25 = 25%, UT-35 = 35%

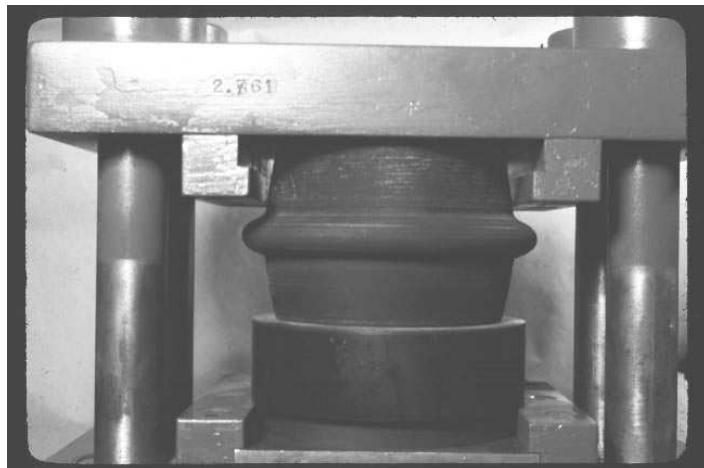

TOOL-O-DIE FILM ROLLS



TOOL-A-THANE TOOL-O-DIE FILM
for both steel and urethane
form dies

ADVANTAGES OF TOOL-A-THANE TOOL-O-FILM

Eliminates scratching/mar-
ring of prefinished material -
vinyl clad, painted, stainless
steels, polished steels.

More accurate bending by
making up for variations in
metal thicknesses.

Aids in reduction of wear on metal to metal die contact.
Easy installation by just laying over bottom/female die.

TOOL-A-THANE URETHANE TOOL-O-DIE FILM ROLLS

Catalog #	Thickness	Width	Length	Grade	Price/Roll	Price/Foot
5002015	.020"	2"	50'	UT-15	49.60	
5002215	.020"	3"	50'	UT-15	66.65	
5002415	.020"	5"	50'	UT-15	116.16	
2002315	.063"	24"	90'	UT-15		43.06
2012315	.125"	24"	45'	UT-15		50.61
2012415	.125"	36"	45'	UT-15		66.60



TOOL-A-THANE URETHANE CUSTOM WIPERS

Custom Tool-a-thane Wipers are one of our specialties.
As an example: 1/2" x 2-1/8" x 80" Wipes coil stock clean
from all fluids. Contact UTEC for pricing and delivery.

**TOOL-A-THANE URETHANE
UT-5 WIPER BLADES**

For wipe dies, wear strips, Oversized for 1/4 x 1 milled area c'bored holes in standard position for mounting, screws available.

	Size	Price
1/4" x 1" x 12"	with c'bored holes	11.18
1/4" x 1" x 12"	without holes	9.32
1/4" x 1" x 24"	without holes	16.70
7/8" x 1" x 12"	with holes	83.00
1" x 1" x 12"	without c'bored holes	32.61

UT-100 ADHESIVE

Equal two part A & B mixture, in container A with stirring stick, 1" brush, instructions; pot life 45 minutes. Bonds Tool-A-Thane to: Tool-A-Thane, steel, wood, etc.

	Size	Price
1 Pint Kit		37.35

UT-200 ADHESIVE TAPE

Two sided adhesive tape for holding Tool-A-Thane for general positioning.

	Size	Price
Clamping Tape 1" x 36 yards		37.20

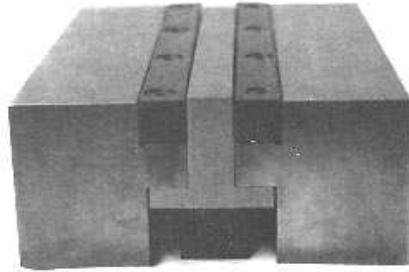
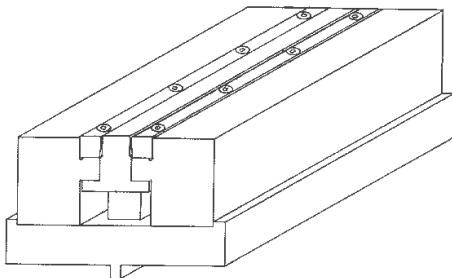

**TOOL-A-THANE URETHANE WIPE UP DIE
ADVANTAGES OF TOOL-A-THANE URETHANE WIPE UP DIE**

Easy to make	Excellent accuracy
Standard Die Design readily available	Reduced set up time
Standard Components readily available	Minimal Marring
Allows for metal thickness variations	Non-Scratching

CAPACITIES:

The standard wipe up die can be made to form up to 1/8" mild steel. UTEC can supply the **complete** die design using the standard wipe up die concept. This concept uses the standard rails mounted with one of three standard wiper assemblies.

Rails come in one foot sections with 1" x 1" x 12" UT-5 Wiper*, mounted and five mounting holes provided in rails.

**Can be replaced with 1/4" x 1" x 12" UT-5 Wiper assembly or 7/8" x 1" x 12" Tool Steel Wiper Assembly.*

TOOL-A-THANE URETHANE WIPE UP DIE

WIPER BLADE ASSEMBLY

Size	Description	Rating	Price/Ft.
1" x 1" x 12"	UT-5 Wiper Assembly	16 ga.	36.96
1/4" x 1" x 12"	UT-5 Wiper Assembly	20 ga.	87.00
7/8" x 1" x 12"	Tool Steel Wiper Assembly	1/8" MS	87.00

TOOL-A-THANE URETHANE WIPE UP DIE

Description	Price/Ft.
Tool-A-Thane Urethane Wipe Up Die Rail Complete	325.00
Design Charge for Standard Wipe Up Die Using Standard Parts	150.00

TOOL-A-THANE "EXACT A FORM" PAD

For use in conventional female V Die for bending and forming

Advantages of "Exact-A-Form" Pad

Eliminates scratching and marring of all prefinished materials including vinyl clad, painted, stainless and others.

Forms more accurate bends than with conventional air form V Dies. Possible to form sharper inside radius on bend line.

Can be used in any press, punch press, or press brake either mechanical or hydraulic. Operated at slow, medium, or high speeds. No wear on punch or V Die being used. No special retainer required.

Easy installation and set-up: Held in place with UT-200 double faced tape. Metal thickness variations and various gages of metal automatically compensated for to allow the forming of many metals in one set up.

Why Choose The "Exact-A-Form" Pad

Extensive tests were made in the development of the Tool-A-Thane "Exact-A-Form" Pad. Many various formulations of urethane were tested along with various shapes.

The special contour shape of the forming area in the pad was developed specifically to give long pad life, minimum strain in the die components as well as the Tool-A-Thane Urethane itself. These properties coupled with the natural qualities of the grades UT-15, UT-25, or UT-35 Tool-A-Thane now provide the excellent wear characteristics required for long pad life, reduced maintenance and downtime, along with economical costing factors.

TOOL-A-THANE "EXACT-A-FORM" PAD

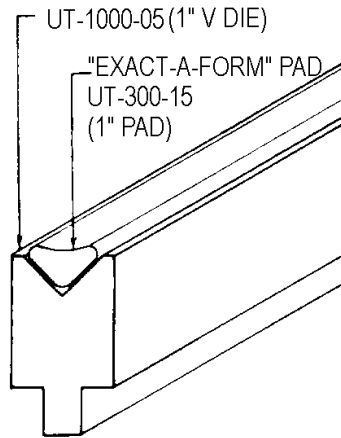
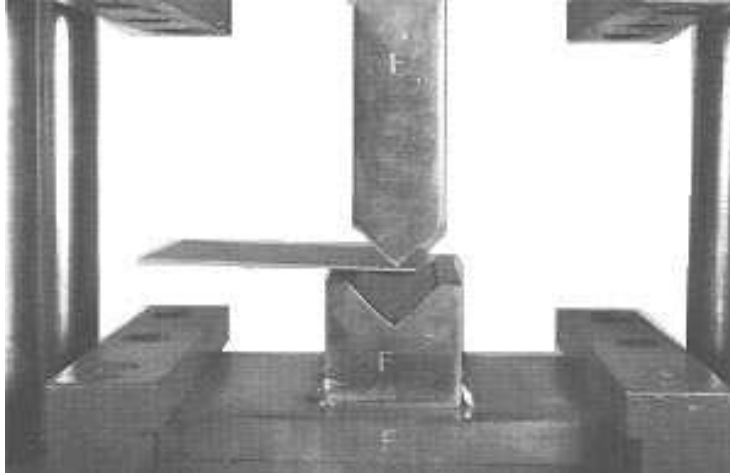

If any technical assistance is required in the use of Urethane in the applications you may have, please consult the factory for assistance. Helping you solve your forming problems is our business. UTEC brings to your door many years of both practical and technical experience in the uses of urethane in the metal forming industry.

EXACT-A-FORM" PAD

Catalog No.	Size	Grade	Length				
			2"	12"	24"	36"	48"
UT-300-15	1"	UT-15	2.50	15.00	30.00	45.00	60.00
UT-300-25	1"	UT-25	2.50	15.00	30.00	45.00	60.00
UT-300-35	1"	UT-35	2.50	15.00	30.00	45.00	60.00
UT-301-15	2"	UT-15	2.50	22.50	45.00	67.50	90.00
UT-301-25	2"	UT-25	2.50	22.50	45.00	67.50	90.00
UT-301-35	2"	UT-35	2.50	22.50	45.00	67.50	90.00

TOOL-A-THANE URETHANE EXACT-A-FORM V DIES
90 DEGREE & 30 DEGREE ACUTE

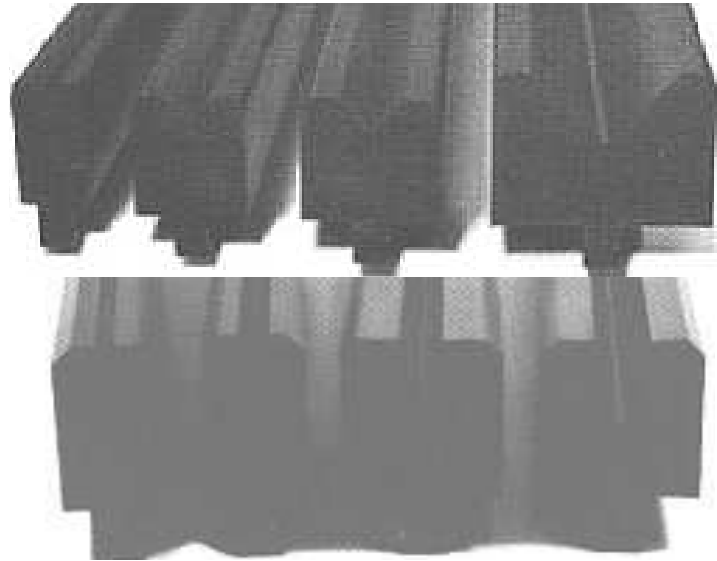
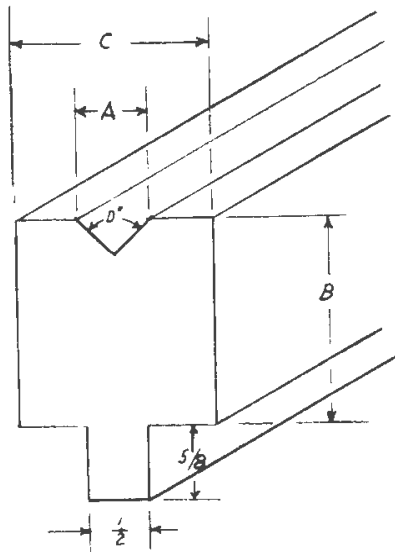

Scratch/Mar free bending in V Type Female Dies made of Tool-A-Thane Urethane grade UT-5; light weight, cost effective

EXACT-A-FORM V DIE SELECTION

Catalog No.	V Opening "A"	Height "B"	Width "C"	Angle "D"	Weight lb/ft.
UT-250-05*	1/4"	1-1/2"	1"	90 degrees	1.20
UT-251-05*	1/4"	1-1/2"	1"	30 degrees	1.20
UT-375-05*	3/8"	1-1/2"	1"	90 degrees	1.20
UT-376-05*	3/8"	1-1/2"	1"	30 degrees	1.20
UT-500-05*	1/2"	1-1/2"	1"	90 degrees	1.20
UT-501-05*	1/2"	1-1/2"	1-5/8"	90 degrees	1.75
UT-625-05*	5/8"	1-1/2"	1-5/8"	90 degrees	1.75
UT-750-05*	3/4"	1-1/2"	1-5/8"	90 degrees	1.75
UT-1000-05*	1"	1-1/2"	1-3/4"	90 degrees	2.00

*V Dies available in one foot increments through 4ft. long.

TOOL-A-THANE URETHANE EXACT-A-FORM V DIES

Catalog No.	Size	12"	24"	36"	48"
UT-250-05	1/4"	46.00	77.00	108.00	139.00
UT-251-05	1/4"	46.00	77.00	108.00	139.00
UT-375-05	3/8"	46.00	77.00	108.00	139.00
UT-376-05	3/8"	46.00	77.00	108.00	139.00
UT-500-05	1/2"	46.00	77.00	108.00	139.00
UT-501-05	1/2"	58.80	102.60	146.40	190.20
UT-625-05	5/8"	58.80	102.60	146.40	190.20
UT-750-05	3/4"	58.80	102.60	146.40	190.20
UT-1000-05	1"	63.25	111.50	159.75	208.00

TOOL-A-THANE URETHANE PRESS BRAKE DIE RETAINERS

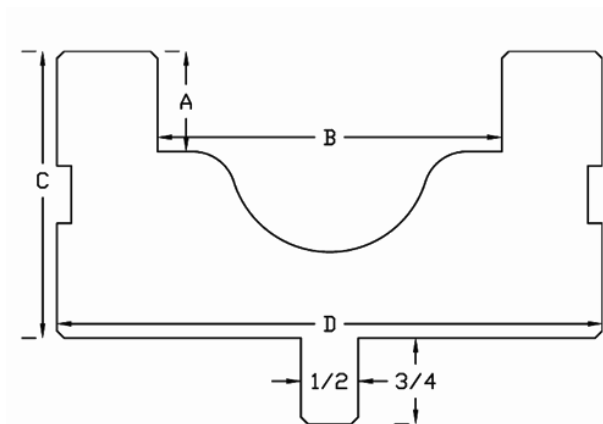

PURPOSE OF PRESS BRAKE DIE RETAINER

The Die Pad Holder nests the forming die pad to hold the high forces of the forming punch during the forming stroke operation.

ADVANTAGES OF PRESS BRAKE DIE RETAINER

- Permits accurate bending with sharp corners
- Oil resistant
- Reduced Setup Costs
- No mar or scratch of polished or prefinished materials
- Forming various shapes & gages of material with one die

PRESS BRAKE DIE RETAINER SELECTION

Size	C	D	Catalog No.
B x A			
1/2" x 1/2"	3"	1-1/2"	UT-0500-0500E
1" x 1/2"	1-3/8"	2-3/4"	UT-01-0500
1-1/2" x 3/4"	1-7/8"	3"	UT-1500-0750E
2" x 3/4"	2-1/4"	3-3/4"	UT-02-0750
3" x 1"	2-1/2"	4-3/4"	UT-03-1000
6" x 1"	4-7/8"	10"	UT-06-1000
12" x 2"	5-7/8"	16"	UT-12-2000

Available in 1 foot increments with no maximum length

TOOL-A-THANE URETHANE PRESS BRAKE DIE RETAINER PRICING

Catalog No.	Size	Pricing
UT-0500-0500E	1/2 X 1/2	\$ 141.00/foot
UT-01-0500	1" X 1/2"	\$110.00 base + \$ 262.00/foot
UT-1500-0750E	3/4 X 1-1/2	\$ 193.20/foot
UT-02-0750	2" X 3/4"	\$120.00 base + \$ 288.00/foot
UT-03-1000	3" X 1"	\$130.00 base + \$ 315.00/foot
UT-06-1000	6" X 1"	\$250.00 base + \$ 775.00/foot
UT-12-2000	12" X 2"	\$345.00 base + \$1410.00/foot

TONNAGE REQUIREMENT FOR PRESS BRAKES PER FOOT LENGTH*

	Holder Catalog No./Size								
Grade	UT-01-0500 (1 X 1/2)			UT-02-0750 (2 X 3/4)			UT-03-1000 (3 X 1)		
	18 ga	16 ga	14 ga	18 ga	16 ga	14 ga	18 ga	16 ga	14 ga
UT-35	3.5	5.0	7.5	3.5	5.0	7.0	3.0	4.5	6.5
UT-25	5.0	7.0	10.0	4.0	6.0	8.0	3.5	5.0	7.0
UT-15	7.5	9.0	13.0	6.5	8.0	11.0	6.0	7.5	10.0

*Gauge determined for 90° bend, one "T" radius with solid die pad

Gauge Capacity for Standard Grades of Tool-A-Thane*

Grade	Size				
	1 x 1/2	2 x 3/4	3 x 1	6 x 1	12 x 2
UT-35	18 ga.	16 ga.	16 ga.	16ga	14 ga
UT-25	16 ga.	14 ga.	14 ga.	10ga	.187
UT-15	14 ga.	12 ga.	12 ga.	.187	.187

*Gauge determined for 90° bend, one "T" radius, solid die pad

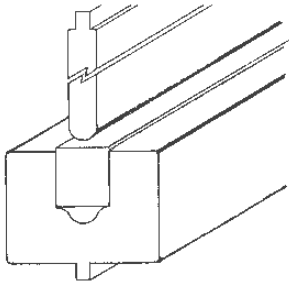

TOOL-A-THANE SOLID URETHANE DIE PAD

Practical for most standard jobs. Pad available in 48" lengths and can be placed end to end for longer than 48" lengths

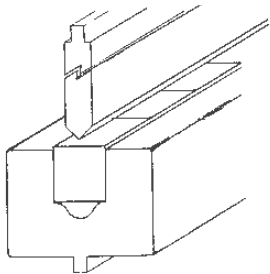

TOOL-A-THANE URETHANE SOLID DIE BLOCKS

Individual blocks placed end to end (2" lg. each) to any length. Recommended where cutting is a potential problem; allows easy and economical replacement of short sections.

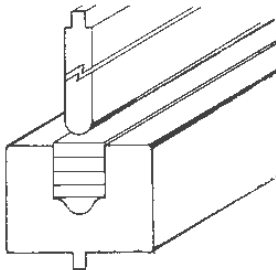

TOOL-A-THANE URETHANE LAYERED DIE PAD

Four layers used where lighter material is being formed and/or reduced tonnage is required.

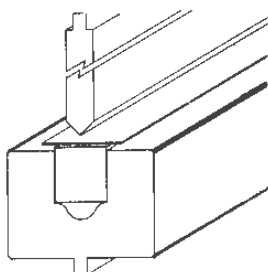

TOOL-A-THANE URETHANE WEAR PADS

1/8" or 1/16" x pad width plus 1" recommended to reduce cutting of main die pad.

TOOL-A-THANE URETHANE DIE PADS/DIE CUSHIONS



RETAINER	PART #	DESCRIPTION	PRICE/FOOT
UT-0500-0500E	30002XX*	1/2" X 1/2" Die Pad	\$ 8.50
UT-01-0500	40811XX*	1" X 1/2" Die Pad	8.07
UT-01-0500	41112XX*	1" X 3/4" Die Pad	12.37
UT-01-0500	40101XX*	1/4" Die Pad Cushion	10.10
UT-1500-0750E	30801XX*	1-1/2" X 3/4" Die Pad	14.85
UT-02-0750	41121XX*	2" X 3/4" Die Pad	19.35
UT-02-0750	41222XX*	2" X 1" Die Pad	24.49
UT-02-0750	40201XX*	1/2" Die Pad Cushion	10.86
UT-03-1000	41231XX*	3" X 1" Die Pad	33.92
UT-03-1000	41332XX*	3" X 1-1/4" Die Pad	41.89
UT-03-1000	40301XX*	3/4" Die Pad Cushion	13.71
UT-06-1000	41261XX*	6" X 1" Die Pad	62.30
UT-06-1000	41362XX*	6" X 1-1/4" Die Pad	74.55
UT-06-1000	41463XX*	6" X 1-1/2" Die Pad	87.10
UT-06-1000	40601XX*	1-1/2" Die Pad Cushion	27.58
UT-12-2000	412121XX*	12" X 2" Die Pad	241.18
UT-12-2000	40401XX*	3" Die Pad Cushion	75.99

*Replace XX with Tool-A-Thane Grade numbers

UT-15 = 15 UT-25 = 25 UT-35 = 35 UT-75 = 75

REPLACEMENT PARTS FOR PRESS BRAKE DIE RETAINERS

RETAINER	PART #	DESCRIPTION	PRICE/EACH
UT-01-0500	9001405	1" X 1/2" Retainer(12")	262.00
UT-01-0500	9001705	1" x 1/2" End Cap	55.00
UT-02-0750	9002405	2" x 3/4" Retainer(12")	288.00
UT-02-0750	9002705	2" x 3/4" End Cap	60.00
UT-03-1000	9003205	3" x 1" Retainer(12")	315.00
UT-03-1000	9003505	3" x 1" End Cap	65.00
UT-06-1000	9006005	6" x 1" Retainer(6")	388.00
UT-06-1000	9006705	6" x 1" End Cap	125.00
UT-12-2000	9012005	12" x 2" Retainer(6")	1410.00
UT-12-2000	9012505	12" x 2" End Cap	172.50
ALL	9001900	Threaded Brass Inserts	.51
ALL	9001901	Cap Screws x 3/8"	.12
ALL	9001902	Cap Screws x 1-1/2"	.21
ALL	9001903	Washers	.18

TOOL-A-THANE URETHANE SPRING GAGES

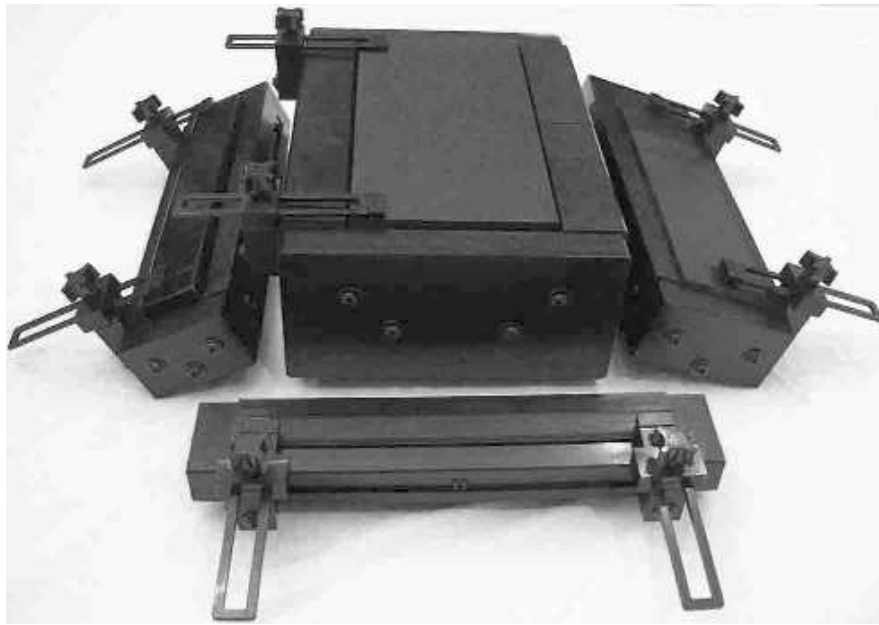

TOOL-A-THANE URETHANE SPRING GAGES

RETAINER	PART #	DESCRIPTION	PRICE/EACH
UT-0500-0500	4000501	1/2" X 1/2" Spring Gage	\$ 85.00
UT-01-0500	4010501	1" X 1/2" Spring Gage	75.00
UT-1500-0750	4040501	1-1/2" X 3/4" Spring Gage	85.00
UT-02-0750	4020751	2" X 3/4" Spring Gage	85.00
UT-03-1000	4031000	3" X 1" Spring Gage	85.00
UT-06-1000	4061000	6" X 1" Spring Gage	95.00
UT-12-2000	4122000	12" X 2" Spring Gage	105.00

REPLACEMENT PARTS FOR SPRING GAGES

RETAINER	PART #	DESCRIPTION	PRICE/EACH
UT-0500-0500	9000805	1/2" X 1/2" Spring Gage Body	\$ 12.15
UT-01-0500	9001805	1" X 1/2" Spring Gage Body	11.85
UT-1500-0750	9004805	1-1/2" X 3/4" Spring Gage Body	12.15
UT-02-0750	9002805	2" X 3/4" Spring Gage Body	12.15
UT-03-1000	9003805	3" X 1" Spring Gage Body	12.15
UT-06-1000	9006805	6" X 1" Spring Gage Body	12.87
UT-12-2000	9012805	12" X 2" Spring Gage Body	14.95
ALL	900X705	Spring Gage Stop	14.16
ALL	900X805	Spring Gage Body Clamp	4.26
ALL	900X905	Spring Gage Body Stop Clamp	7.80
ALL	9001900	Threaded Brass Inserts	.51
ALL	9001902	Cap Screws X 1-1/2"	.21
ALL	9001903	Washers 1/16"	.18
ALL	9001904	Thumb Knob	2.94

**TOOL-A-THANE URETHANE "SPLIT PADS"
FOR PRESS BRAKE DIE RETAINERS**

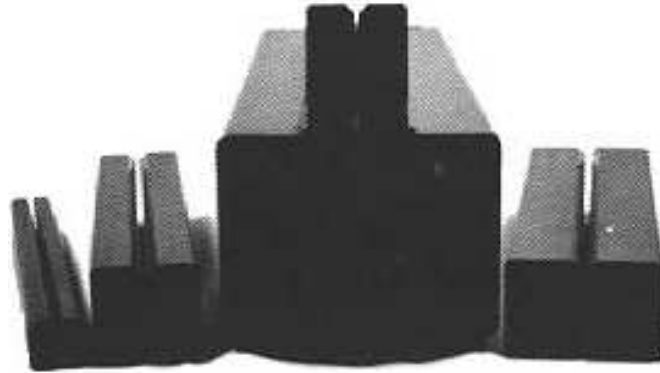
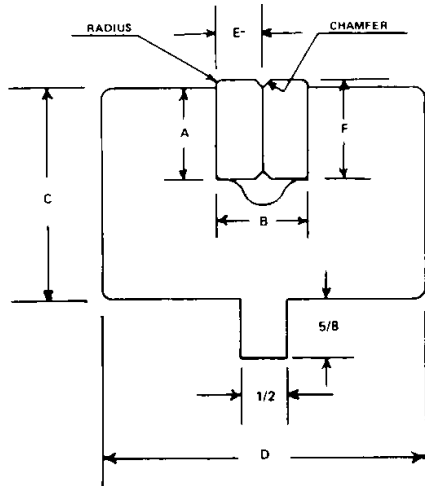

Scratch free bending both 90 degree and acute angles in regular Press Brake Die Retainers

ADVANTAGES OF TOOL-A-THANE URETHANE "SPLIT PADS"

- | | | |
|------------------------------------------------------------|----------------|--------------------|
| Reduced Tonnage | Light Weight | Excellent Accuracy |
| Reduce Set Up Time | Non-Scratching | Non Marring |
| Acute Angles with no damage from over deflection or strain | | |

TOOL-A-THANE URETHANE "SLIT PADS"

Selection Catalog no.	Width (E) x Height (F)	Length				
		2"	12"	24"	36"	48"
UT-0510-00	1/2" X 1"	1.68	8.07	16.14	24.21	32.28
UT-1020-00	1" X 2"	3.54	20.75	41.50	62.25	83.00

Available in 12" lengths to 48", longer lengths butt end to end

TOOL-A-THANE WIPE DOWN DIE

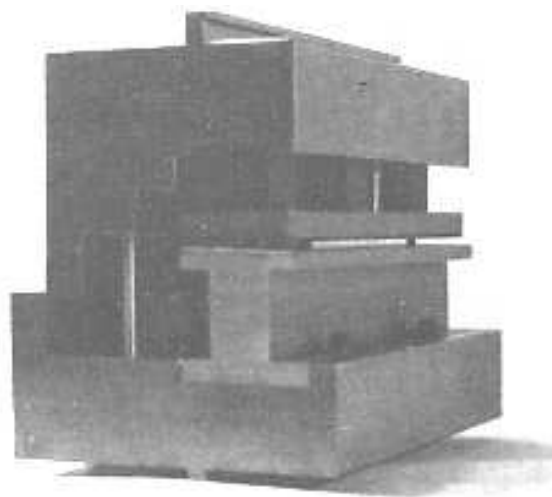
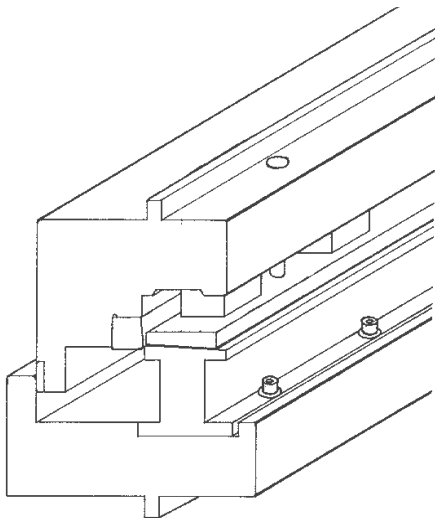

ADVANTAGES OF TOOL-A-THANE URETHANE WIPE DOWN DIE:

- Forms 90 degree bends with no sheet "flip up"
- Easy to replace wipers & springs High Blank holding pressure

Non Scratching Main Die 12" Sections only Non Marring
 Simple Setup Both UT-5 & Steel Wipers Excellent Accuracy
 Easy to replace wipers & springs

CAPACITIES WITH:

Standard 1" x 1" x 12" UT-5 Wiper, supplied with die - 16ga
 1/4" x 1" x 12" UT-5 Wiper - 20 ga
 7/8" x 1" x 12" Tool Steel Wiper - 1/8" mild steel

AVAILABILITY:

Basic die in one foot sections, except for forming horn, which is supplied in one piece x length of die ordered. Standard die comes with 1" x 1" x 12" UT-5 Wiper Blades. If other wiper assemblies required, specify. Order die now and add additional 12" sections later.

TOOL-A-THANE URETHANE WIPE DOWN DIE

DESCRIPTION	PRICE/FT
Tool-A-Thane Urethane Wipe Down Die Complete	\$2390.00
Tool-A-Thane Urethane Wipe Down Die Top Complete	1935.00
Tool-A-Thane Urethane Wipe Down Die Bottom	1610.00
Tool-A-Thane Urethane Forming Horn Complete	925.00

TOOL-A-THANE FORM/EMBOSS/BLANK DIE

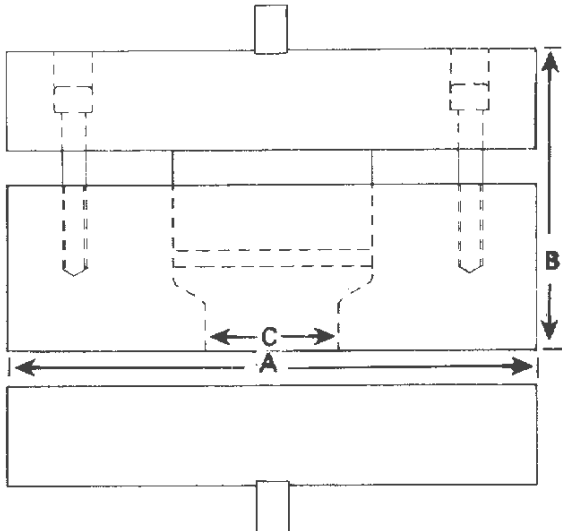

PURPOSE AND ADVANTAGES OF FORM/EMBOSS/BLANK DIES

Emboss, Blank or Form while only building half a die.
 Extremely lightweight for easy set-ups and dismantling.
 Minimum down time to replace forming pad.
 No marring or scratching of polished/prefinished materials.
 Design assistance for steel blank section, consult factory.

FORM/EMBOSS/BLANK DIE SELECTION

Size Working Diameter "C"	Size Overall Diameter "A"	Size Overall Height "B"	Catalog #	Price
2"	8"	4-1/2"	FEB 2000	3950.00
4"	12"	5"	FEB 4000	5910.00
6"	16"	6"	FEB 6000	7990.00

UTEC SPRINGBACK DEVELOPMENT SYSTEMS TOOLS/KITS/SERVICES

MEASURING KIT SYSTEM:

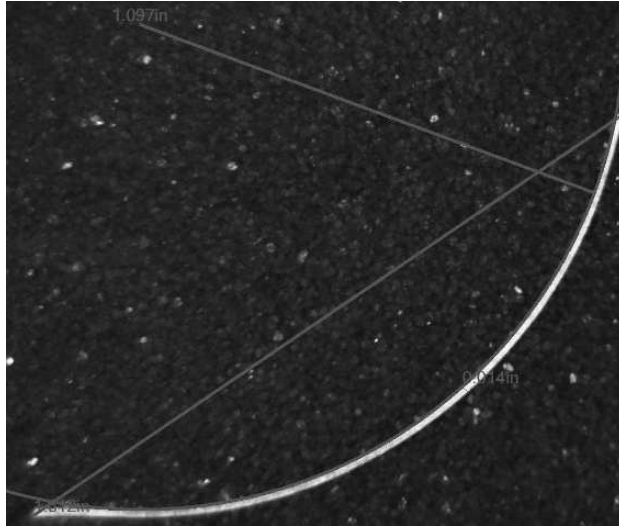
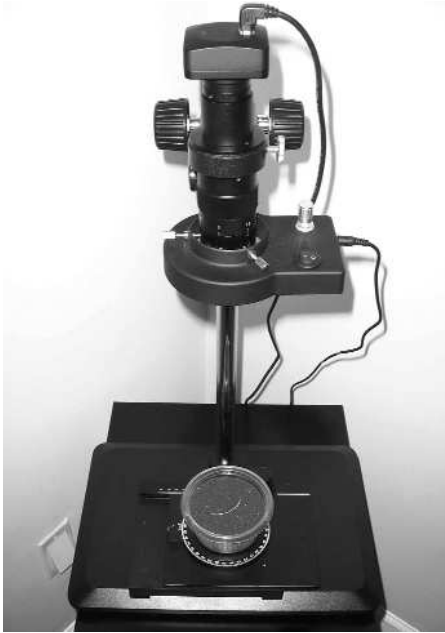

Measuring Kit System includes Microscope, Stand, Lighting, Camera, Camera Software, Adjustable Stage, Part Container, Spreadsheet for Punch Diameter/Part Diameter. Springback of Material to determine Punch Diameter for any given Part Diameter. \$1500.00/Lot

DEVELOPMENT RETAINER SYSTEMS WITH DIE PADS, CUSHION PADS, WEAR PADS:



UT-01-0500 X 12", 1" X 1/2" Press Brake Die Retainer	\$ 372.00/Ea.
1/2" X 1" X 12" Die Pads, one each in UT-15, UT-25, UT-35, UT-05	\$ 32.28/Lot
3/4" X 1" X 12" Die Pads, one each in UT-15, UT-25, UT-35, UT-05	\$ 49.48/Lot

1/4" Diameter X 12" Die Pad Cushions, one each in UT-15, UT-25, UT-35, UT-05	\$ 40.40/Lot
.020" X 2" X 50' Wear Pad Roll, UT-15	\$ 49.60/Ea.
Subtotal	\$ 543.76/Lot
Development Retainer Discount Less 20%	\$-108.75/Lot
Net Subtotal	\$ 435.01/Lot
UT-02-0750 X 12", 2" X 3/4" Press Brake Die Retainer	\$ 408.00/Ea.
3/4" x 2" x 12" Die Pads, one each in UT-15, UT-25, UT-35, UT-05	\$ 77.40/Lot
1" X 2" X 12" Die Pads, one each in UT-15, UT-25, UT-35, UT-05	\$ 97.96/Lot
1/2" Diameter X 12" Die Pad Cushions, one each in UT-15, UT-25, UT-35, UT-05	\$ 43.44/Lot
.020" X 3" X 50' Wear Pad Roll, UT-15	\$ 66.65/Ea.
Subtotal	\$ 93.45/Lot
Development Retainer Discount Less 20%	\$-138.69/Lot
Net Subtotal	\$ 554.76/Lot
UT-03-1000 X 12", 3" X 1" Press Brake Die Retainer	\$ 445.00/Ea.
1" X 3" X 12" Die Pads, one each in UT-15, UT-25, UT-35, UT-05	\$ 135.68/Lot
1-1/4" X 3" X 12" Die Pads, one each in UT-15, UT-25, UT-35, UT-05	\$ 167.56/Lot
3/4" Diameter X 12" Die Pad Cushions, one each in UT-15, UT-25, UT-35, UT-05	\$ 54.84/lot
.020" X 5" X 50' Wear Pad Rolls, UT-15	\$ 105.54/Ea.
Subtotal	\$ 908.62/Lot
Development Retainer Discount Less 20%	\$-181.72/Lot
Net Subtotal	\$ 726.90/Lot
UT-06-1000 X 12", 6" X 1" Press Brake Die Retainer	\$1025.00/Ea.
1" X 6" X 12" Die Pads, one each in UT-15, UT-25, UT-35, UT-05	\$ 249.20/Lot
1-1/4" X 6" X 12" Die Pads, one each in UT-15, UT-25, UT-35, UT-05	\$ 298.20/Lot
1-1/2" Diameter X 12" Die Pad Cushion, one each in UT-15, UT-25, UT-35, UT-05	\$ 10.32/Lot
1/8" X 8" X 48" Wear Pad Sheet, UT-15	\$ 73.39/Ea.
Subtotal	\$1756.11/Lot
Development Retainer Discount Less 20%	\$-351.22/Lot
Net Subtotal	\$1404.89/Lot
4 Retainer Subtotal	\$3121.56/Lot
4 RETAINER ADDITIONAL DISCOUNT LESS 12.5%	\$-390.19/Lot
NET GRAND TOTAL 4 DEVELOPMENT RETAINER SYSTEM	\$2731.37/Lot

**DEVELOPMENT PUNCH SYSTEMS WITH SAFETY TANG X 2" SET
INCLUDES:**

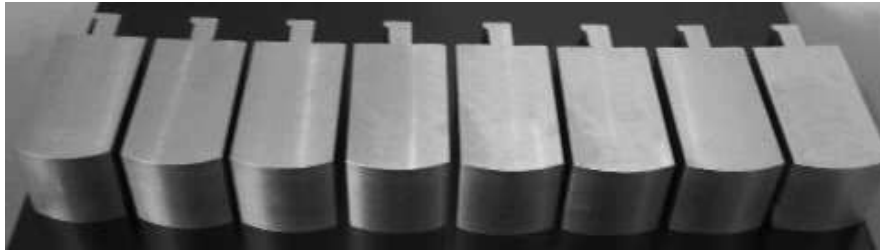

14	Punch Set Master Complete-.015"R, .500"R, 1.000"R, 2.000"R, 3.000"R, 4.000"R, 5.000"R, 6.000"R, 7.000"R, 8.000"R, 9.000"R, 10.000"R, 11.000"R, 12.000"R	\$1680.00/Lot
7	Punch Set Master Odd-.015"R, 1.000"R, 3.000"R, 5.000"R, 7.000"R, 9.000"R, 11.000"R	\$ 840.00/Lot
7	Punch Set Master Even-.500"R, 2.000"R, 4.000"R, 6.000"R, 8.000"R, 10.000"R, 12.000"R	\$ 840.00/Lot
8	Punch Set 0015-.015"R, .032"R, .062"R, .125"R, .187"R, .250"R, .312"R, .375"R	\$ 960.00/Lot
4	Punch Set 0015 Odd-.015"R, .062"R, .187"R, .312"R	\$ 480.00/Lot
4	Punch Set 0015 Even-.032"R, .125"R, .250"R, .375"R	\$ 480.00/Lot
8	Punch Set 0500-.500"R, .562"R, .625"R, .687"R, .750"R, .812"R, .875"R, .937"R	\$ 960.00/Lot
4	Punch Set 0500 Odd-.500"R, .625"R, .750"R, .875"R	\$ 480.00/Lot
4	Punch Set 0500 Even-.562"R, .687"R, .812"R, .937"R	\$ 480.00/Lot
8	Punch Set 1000-1.000"R, 1.125"R, 1.250"R, 1.375"R, 1.500"R, 1.625"R, 1.750"R, 1.875"R	\$ 960.00/Lot
4	Punch Set 1000 Odd-1.000"R, 1.250"R, 1.500"R, 1.750"R	\$ 480.00/Lot
4	Punch Set 1000 Even-1.125"R, 1.375"R, 1.625"R, 1.875"R	\$ 480.00/Lot
8	Punch Set 2000-2.000"R, 2.125"R, 2.250"R, 2.375"R, 2.500"R, 2.625"R, 2.750"R, 2.875"R	\$ 960.00/Lot
4	Punch Set 2000 Odd-2.000"R, 2.250"R, 2.500"R, 2.750"R	\$ 480.00/Lot
4	Punch Set 2000 Even-2.125"R, 2.375"R, 2.625"R, 2.875"R	\$ 480.00/Lot
8	Punch Set 3000-3.000"R, 3.125"R, 3.250"R, 3.375"R, 3.500"R, 3.625"R, 3.750"R, 3.875"R	\$ 960.00/Lot
4	Punch Set 3000 Odd-3.000"R, 3.250"R, 3.500"R, 3.750"R	\$ 480.00/Lot
4	Punch Set 3000 Even-3.125"R, 3.375"R, 3.625"R, 3.875"R	\$ 480.00/Lot
8	Punch Set 4000-4.000"R, 4.125"R, 4.250"R, 4.375"R, 4.500"R, 4.625"R, 4.750"R, 4.875"R	\$ 960.00/Lot
4	Punch Set 4000 Odd-4.000"R, 4.250"R, 4.500"R, 4.750"R	\$ 480.00/Lot

4	Punch Set 4000 Even-4.125"R, 4.375"R, 4.625"R, 4.875"R	\$ 480.00/Lot
8	Punch Set 5000-5.000"R, 5.125"R, 5.250"R, 5.375"R, 5.500"R, 5.625"R, 5.750"R, 5.875"R	\$ 960.00/Lot
4	Punch Set 5000 Odd-5.000"R, 5.250"R, 5.500"R, 5.750"R	\$ 480.00/Lot
4	Punch Set 5000 Even-5.125"R, 5.375"R, 5.625"R, 5.875"R	\$ 480.00/Lot
8	Punch Set 6000-6.000"R, 6.125"R, 6.250"R, 6.375"R, 6.500"R, 6.625"R, 6.750"R, 6.875"R	\$ 960.00/Lot
4	Punch Set 6000 Odd-6.000"R, 6.250"R, 6.500"R, 6.750"R	\$ 480.00/Lot
4	Punch Set 6000 Even-6.125"R, 6.375"R, 6.625"R, 6.875"R	\$ 480.00/Lot
8	Punch Set 7000-7.000"R, 7.125"R, 7.250"R, 7.375"R, 7.500"R, 7.625"R, 7.750"R, 7.875"R	\$ 960.00/Lot
4	Punch Set 7000 Odd-7.000"R, 7.250"R, 7.500"R, 7.750"R	\$ 480.00/Lot
4	Punch Set 7000 Even-7.125"R, 7.375"R, 7.625"R, 7.875"R	\$ 480.00/Lot
8	Punch Set 8000-8.000"R, 8.125"R, 8.250"R, 8.375"R, 8.500"R, 8.625"R, 8.750"R, 8.875"R	\$ 960.00/Lot
4	Punch Set 8000 Odd-8.000"R, 8.250"R, 8.500"R, 8.750"R	\$ 480.00/Lot
4	Punch Set 8000 Even-8.125"R, 8.375"R, 8.625"R, 8.875"R	\$ 480.00/Lot
8	Punch Set 9000-9.000"R, 9.125"R, 9.250"R, 9.375"R, 9.500"R, 9.625"R, 9.750"R, 9.875"R	\$ 960.00/Lot
4	Punch Set 9000 Odd-9.000"R, 9.250"R, 9.500"R, 9.750"R	\$ 480.00/Lot
4	Punch Set 9000 Even-9.125"R, 9.375"R, 9.625"R, 9.875"R	\$ 480.00/Lot
8	Punch Set 10000-10.000"R, 10.125"R, 10.250"R, 10.375"R, 10.500"R, 10.625"R, 10.750"R, 10.875"R	\$ 960.00/Lot
4	Punch Set 10000 Odd-10.000"R, 10.250"R, 10.500"R, 10.750"R,	\$ 480.00/Lot
4	Punch Set 10000 Even-10.125"R, 10.375"R, 10.625"R, 10.875"R	\$ 480.00/Lot
8	Punch Set 11000-11.000"R, 11.125"R, 11.250"R, 11.375"R, 11.500"R, 11.625"R, 11.750"R, 11.875"R	\$ 960.00/Lot
4	Punch Set 11000 Odd-11.000"R, 11.250"R, 11.500"R, 11.750"R,	\$ 480.00/Lot
4	Punch Set 11000 Even-11.125"R, 11.375"R, 11.625"R, 11.875"R	\$ 480.00/Lot
8	Punch Set 12000-12.000"R, 12.125"R, 12.250"R, 12.375"R, 12.500"R, 12.625"R, 12.750"R, 12.875"R	\$ 960.00/Lot

4 Punch Set 12000 Odd-12.000"R,12.250"R, 12.500"R,12.750"R	\$ 480.00/Lot
4 Punch Set 12000 Even-12.125"R,12.375"R, 12.625"R,12.875"R	\$ 480.00/Lot
14 - 8 Punch Set Total	\$13440.00/Lot
14 - 8 Punch Set Discount Less 15%	\$-1008.00/Lot
Net Grand Total For 14 Punch Sets	\$12424.00/Lot
14 - 4 Punch Sets Odd or Even Total	\$ 6720.00/Lot
14 - 4 Punch Sets Odd or Even Discount Less 15%	\$-1008.00/Lot
Net Grand Total for 14 4 Punch Sets Odd or Even	\$ 5712.00/Lot
1 Punch Master with Flat Blank Face -Aluminum	\$ 70.00/Ea.
machining purposes - Tool-A-Thane Urethane	\$ 50.40/Ea.

SPRINGBACK CLUB:

Submit one Springback Development Using the above tools for your Springback Development and get access to one available Springback Development that is one the Springback Club Listing. Subject to Availability. \$ 0.00/Ea.

If you don't have the above items to do a Springback Development, pay for one Springback Development that is available at the club \$ 350.00/Ea.

For a brand new Springback Development customer to provide specified material with detailed specs for that material. UTEC to do new Springback Development for your radius and other \$ 475.00/Lot

Springback Development to provide all the information needed that is on our Spreadsheet used for the Springback Developments.

TECHNICAL SUPPORT:

Technical Support for Development Retainers/ Punch Sets/Measuring Kit System. When purchasing Development Retainers and/or Development Punch Set/s and/or Measuring Kit System, first 3 months technical support is free. \$ 360.00/yr.
or \$ 50.00/mnth

Technical Support Onsite, minimum one day and all expenses. Onsite Technical Support doesn't apply against 3 months free technical support \$ 850.00/Day

ADVANTAGES OF USING TOOL-A-THANE URETHANES:

1. Tool-A-Thane will not scratch or mar the surface of the material being formed.
2. In many cases tooling costs can be reduced, especially for short run jobs and prototype work.
3. In standard Tool-A-Thane press brake dies several punches can be used, thereby reducing the die change time as well as the tooling cost for each job.
4. It has been noted that metal fatigue has been reduced or minimized.
5. Blanks are kept from slipping during the forming operation.
6. Use of Tool-A-Thane urethane dies allow material to vary in its thickness without damage to the dies or the press being used.
7. Developments for spring back can be done in 2" long section.
8. Punches need not be hardened.

TOOL-A-THANE URETHANE DIE DESIGNS

The following pages show some of the die designs that have been used successfully. Grade selection for each die depends on such variables as material thickness, production quantities, definition required, springback of material and others.

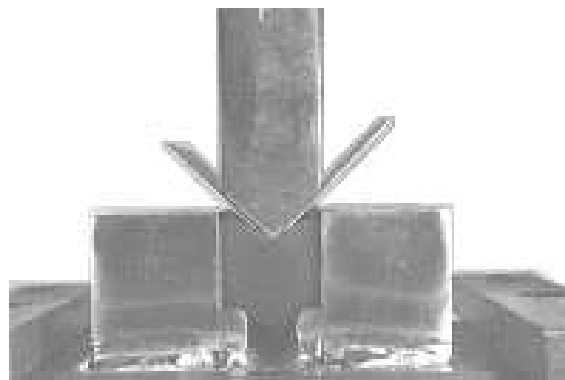
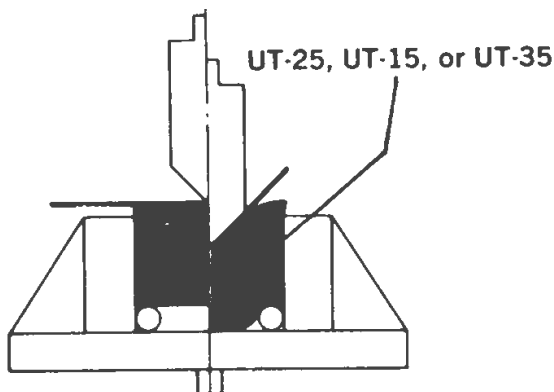

V-FORMING: One of the first and simplest applications, Tool-A-Thane used in a press brake die retainer for forming single V bends. Advantages of this type of forming include: Sharper inside radius than with conventional tooling; Allows for material thickness variation; Simplicity of set-up; By changing V-punch only, various angles can be made using the same female die section, although gage of material may change.

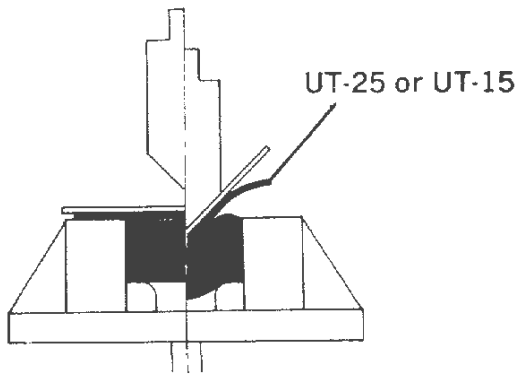

WEAR PADS: Wear Pads are thin sheets of Tool-A-Thane, normally placed on the die pad in order to protect the die pads' surface from early cutting or wear. Advantage lies in the replacement cost of the wear pad being far less than that of the die pad. Normally 1/16" or 1/8" thick.

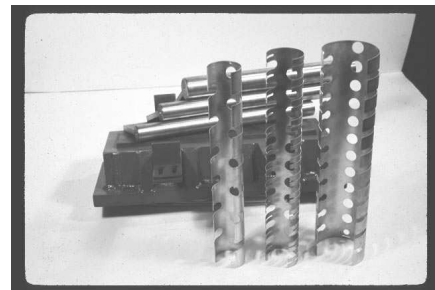
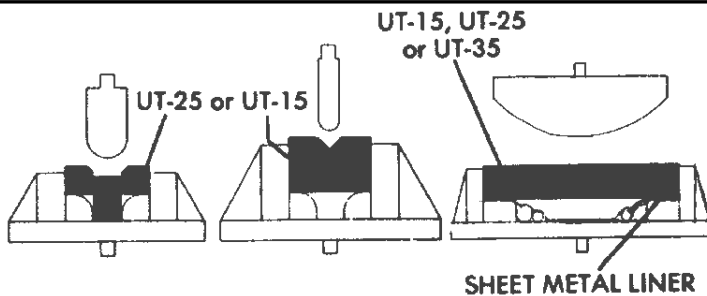

RADIUS FORMING: Both standard and specially fabricated press brake die retainers can be used in this application as shown. Deflector bars help reduce strain on urethane by forming shape in bottom of retainer. Layered or a split pad arrangement also reduces strain on urethane for optimum life. Multiple grades also can be used in one die.

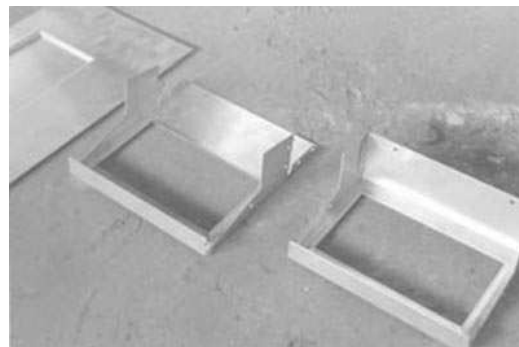
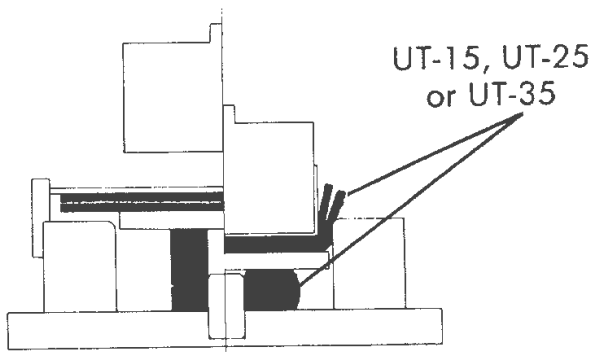

FOLDING DIE: Wrapping (folding) action used for soft, high polished, or patterned material, which can not stand any rubbing action against it without marking. Tool-A-Thane folds material to punch with no wiping action.

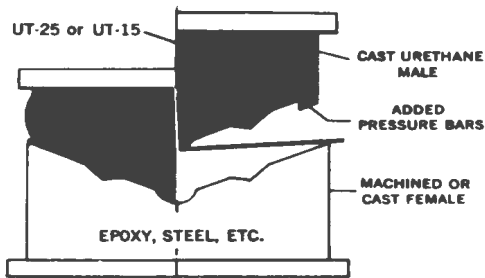

CAST MALE: Tool-A-Thane used as male punch. No critical line up is necessary between male and female sections. Machined or epoxy cast female is used as the mold for the casting of urethane punch. Design allows bottoming with pressure while material thickness variation is automatically allowed for. Die can be used for either low or high production runs. Die design allows for substantial reduction in tool cost as compared to conventional methods.

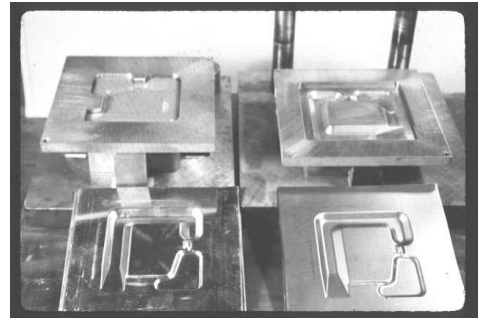
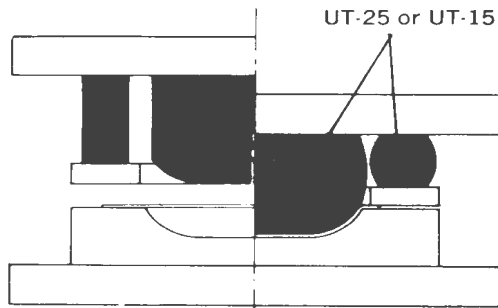

DRAW DIES: In this application either the male punch or the female section can be made of Tool-A-Thane urethane, depending on the requirements of the part. Prefinished material can be formed with no marking of the surface which contacts the urethane side of the die. Die will compensate for material thickness variations. Critical mating of the male and female sections is eliminated. Steel section of the die becomes the "Sizing Mandrel" due to the flexible urethane section moving to allow for any variations.

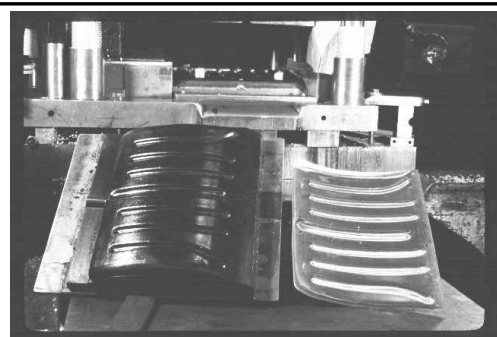
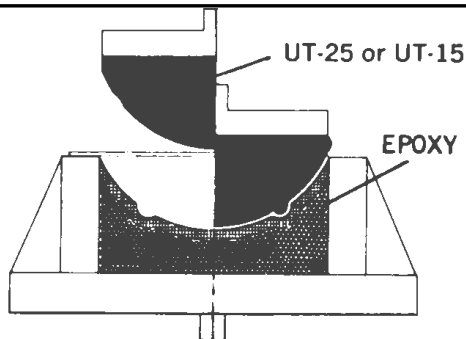

FORM AND BULGE DIE: Another type of cast punch where only general contour is achieved in the urethane section. Forming of the shaped or embossed areas is achieved by squeeze on the urethane causing urethane movement to void areas in the female section.

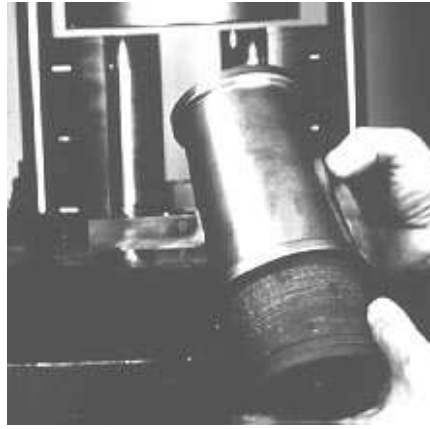
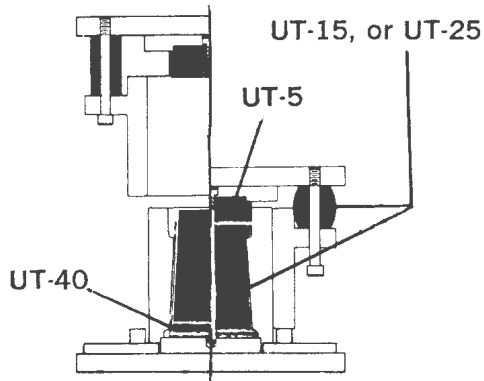

BULGING DIES: Highly efficient method of producing complex shapes that by conventional methods would be extremely costly. Tool-A-Thane offers far superior life as compared to rubber or neoprene. Normally, no shaping of the urethane is required. Major consideration is one of selection of the grade of urethane, based on not over deflecting the urethane and on definition achieved without over straining, to achieve shape required.

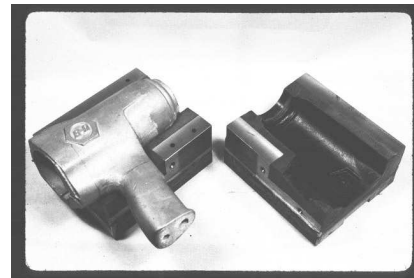
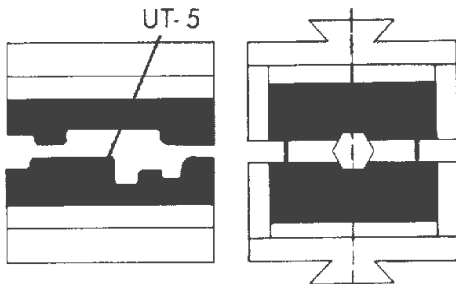

CLAMPING JAWS AND FIXTURES: Highly successful method of holding various parts for subsequent machining operations. Jaws and Fixtures can be machined or cast to shape depending on the complexity of the part to be held. Main advantage is that Tool-A-Thane, because of its' flexibility, can allow for variation in the individual piece parts, while still maintaining machining tolerances.

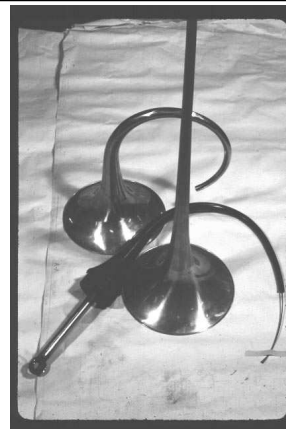
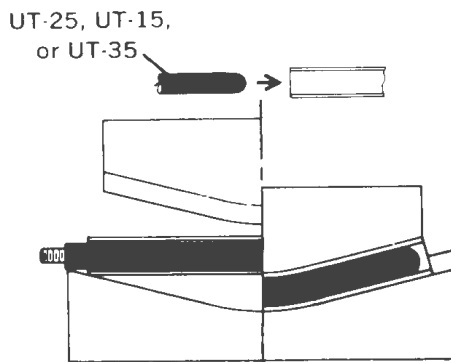

MANDRELS: Urethane being used as inserts to aid in the reduction of distortion while bending tubes and other hollow shapes.

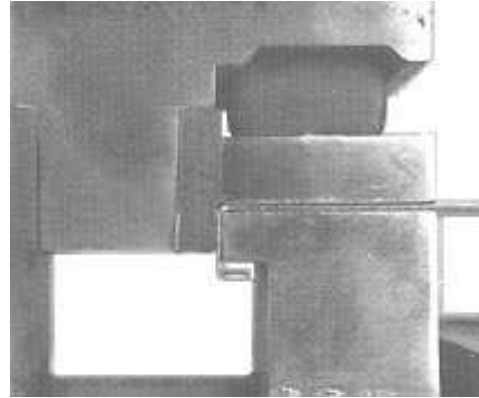
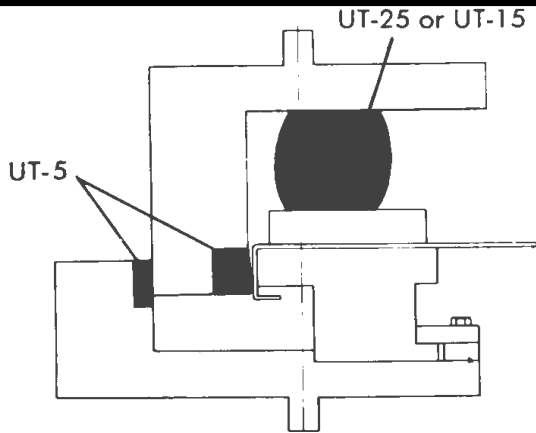

WIPE-DOWN DIE: A method where sheet flip up is eliminated. Pressure pad is used for holding on to the blank during the forming of the flange. Normally UT-5 material is used for the wiper blade. This design is not limited to light gauges, but has been used successfully in heavier gages up to 14 gage.

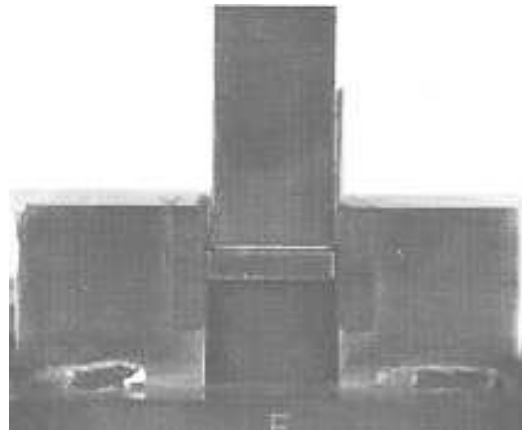
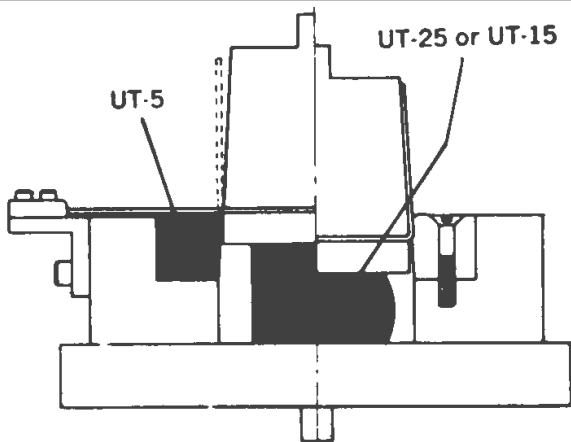

U WIPING DIE: This die is an off shoot of the wipe-down die. The bottom of the U is held flat by the pressure pad technique, while the flanges are wiped up as in a wipe type die.

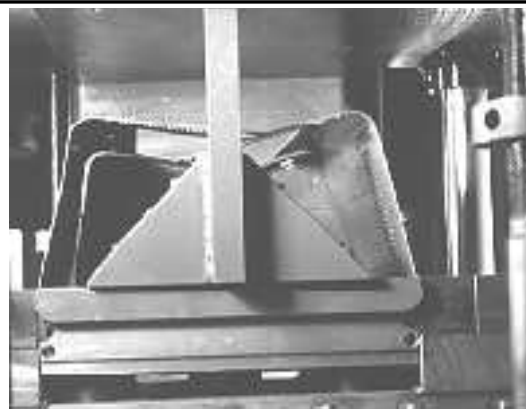
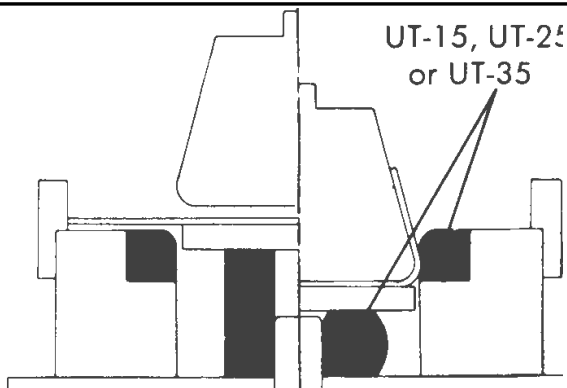

U FORMING DIE: This design uses softer Tool-A-Thanes to wipe - form flanges where larger inside radius is required (usually 6 to 20 times metal thickness). Over forming past 90 degrees is easily obtainable while still forming two bends in one hit.

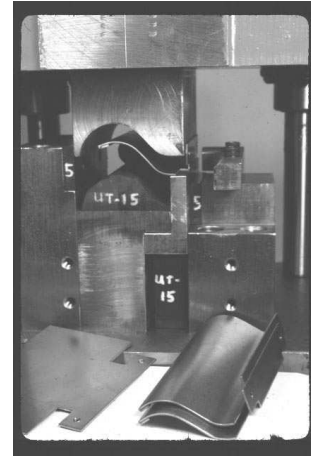
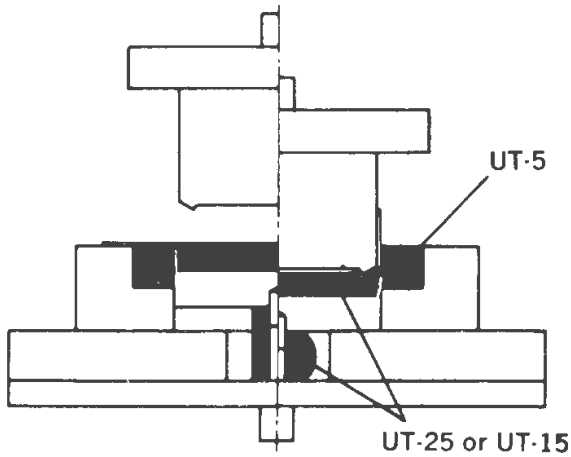

COMBINATION FORM DIES: In previous die designs basic simplicity is achieved. On occasion two or more of these designs have been combined into one die. For example, it is possible to make a multiple flange form die that is also capable of doing embossing at the bottom of the stroke.

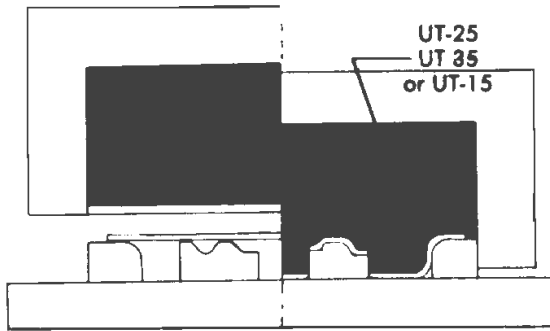

BLANK AND EMBOSS DIE: Method for forming ribs, pockets, or other shapes as well as blanking. Tool-A-Thane contained requires higher tonnages, but is good for production run tooling. Tool-A-Thane can be without retainer, lowers tonnage required, but then is limited to low production.

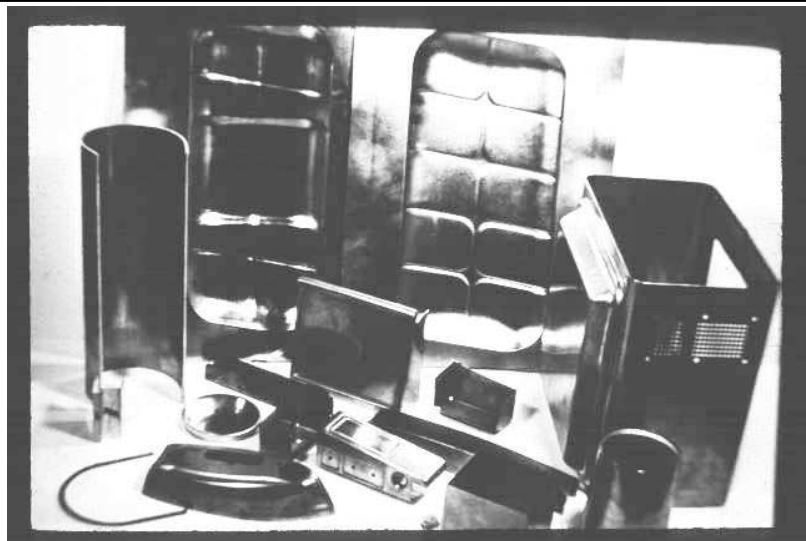

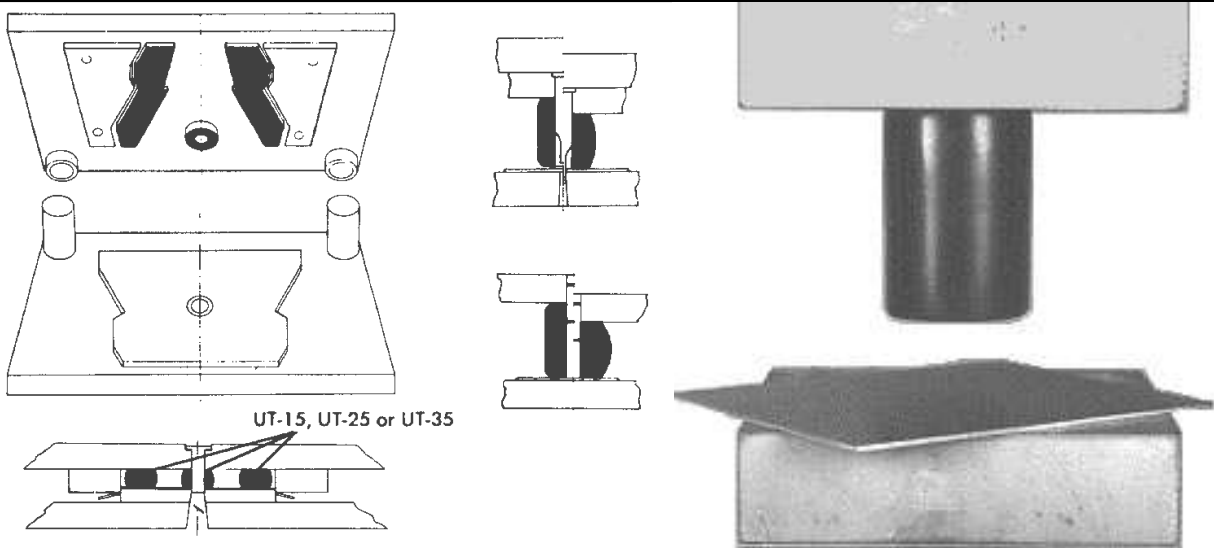

SPRINGS, STRIPPERS & PRESSURE PADS: A new and advantageous application. The use of Tool-A-Thane springs does not require the use of set screws or stripper bolts for mounting. Springs are a ring fit with body diameter, of standard punches or dowel pins. Springs develop high pressure, positive stripping, dampen punch vibration, will not shrapnelize, and are simple to install. Standard line of Tool-A-Thane springs and strippers is grade UT-15; however, special pressure requirements may dictate other grade selections. Consult Tool-A-Thane Springs and Strippers price list for size availability, pressure developed per 1/8" deflection, minimum center to center distance, etc. Where high holding or stripping pressures are demanded, bar stock can meet the need. Bars of 1 x 1, 2 x 2, 3 x 2, and 3 x 3 as well as others can be used to replace large numbers of springs. Higher pressures will be achieved, while utilizing a smaller area. Pressures can go from 4000 lbs. per 1/8" deflection to almost 100,000 lbs. per 1/8" deflection. See pressure chart.

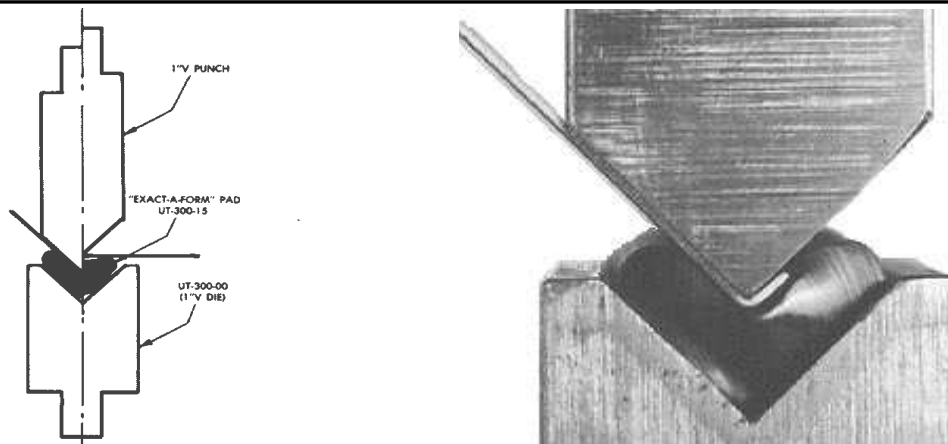

EXACT-A-FORM PADS: Forming various bends while still using conventional V Dies and punches, 1" V Pad to 16 gage mild steel; 2" V Pad to 11 gage mild steel.

NOTES :

QUOTE REQUEST CUSTOM/STANDARD TOOL-A-THANE URETHANE

FROM:

COMPANY :

NAME :

ADDRESS :

CITY, STATE, ZIP

PRINT OF PART:

URETHANE MATERIAL, GRADE, HARDNESS:

PRODUCTION:

TOLERANCES:

COMMENTS:

QUOTE REQUEST FORMING DIES/ENGINEERING SERVICES

FROM:

COMPANY: _____

NAME: _____

ADDRESS: _____

CITY, STATE, ZIP _____

PRINT OF PART: _____

TYPE & THICKNESS OF MATERIAL: _____

MATERIAL THICKNESS: _____

PRODUCTION: _____

TOLERANCES: _____

TYPE OF PRESS: _____

STROKE OF PRESS: _____

SHUT HEIGHT: _____ (stroke down-adj. up)

ADJUSTMENT: _____

COMMENTS: _____

URETHANE TOOLING & ENGINEERING CORP

PHONE: 1(615)510-3009 FAX: 1(615)510-3010

E-MAIL: utec@urethanetooling.com

Website: www.urethanetooling.com

TOOL-A-THANE URETHANE TERMS & TOLERANCES

TERMS: NET 30 DAYS

FOB: SHIPPING POINT

FEDEX or UPS-CUSTOMER ACCOUNT WITH ZIPCODE

ALL OTHER ROUTINGS-COLLECT

TOLERANCES ON TOOL-A-THANE URETHANE:

THICKNESS OR DIAMETER: +or- 2% OR .010" WHICHEVER
GREATER

WIDTH OR LENGTH: + OR - 1/16" TO 1/8"

ORDER INSTRUCTIONS

1. NUMBER OF PIECES
2. CATALOG NUMBER OF ITEM OR SIZE:
THICKNESS, WIDTH, DIAMETER, LENGTH
3. GRADE OF URETHANE DESIRED

NO MINIMUM ORDER REQUIREMENTS



MANUFACTURERS AND SUPPLIERS OF URETHANE
STOCK, MATERIALS, CUSTOM PARTS, TOOLS,
FIXTURES, DIES, RELATED PRODUCTS,
AND ENGINEERING SERVICES